

Алматы (7273)495-231
Ангарск (3955)60-70-56
Архангельск (8182)63-90-72
Астрахань (8512)99-46-04
Барнаул (3852)73-04-60
Белгород (4722)40-23-64
Благовещенск (4162)22-76-07
Брянск (4832)59-03-52
Владивосток (423)249-28-31
Владикавказ (8672)28-90-48
Владимир (4922) 49-43-18
Волгоград (844)278-03-48
Вологда (8172)26-41-59
Воронеж (473)204-51-73
Екатеринбург (343)384-55-89

Ижевск (3412)26-03-58
Иваново (4932)77-34-06
Иркутск (395)279-98-46
Казань (843)206-01-48
Калининград (4012)72-03-81
Калуга (4842)92-23-67
Кемерово (3842)65-04-62
Киров (8332)68-02-04
Коломна (4966)23-41-49
Кострома (4942)77-07-48
Краснодар (861)203-40-90
Красноярск (391)204-63-61
Курск (4712)77-13-04
Курган (3522)50-90-47
Липецк (4742)52-20-81

Магнитогорск (3519)55-03-13
Москва (495)268-04-70
Мурманск (8152)59-64-93
Набережные Челны (8552)20-53-41
Нижний Новгород (831)429-08-12
Новокузнецк (3843)20-46-81
Ноябрьск (3496)41-32-12
Новосибирск (383)227-86-73
Омск (3812)21-46-40
Орел (4862)44-53-42
Оренбург (3532)37-68-04
Пенза (8412)22-31-16
Петрозаводск (8142)55-98-37
Псков (8112)59-10-37
Пермь (342)205-81-47

Ростов-на-Дону (863)308-18-15
Рязань (4912)46-61-64
Самара (846)206-03-16
Саранск (8342)22-96-24
Санкт-Петербург (812)309-46-40
Саратов (845)249-38-78
Севастополь (8692)22-31-93
Симферополь (3652)67-13-56
Смоленск (4812)29-41-54
Сочи (862)225-72-31
Ставрополь (8652)20-65-13
Сыктывкар (8212)25-95-17
Сургут (3462)77-98-35
Тамбов (4752)50-40-97
Тверь (4822)63-31-35

Тольяти (8482)63-91-07
Томск (3822)98-41-53
Тула (4872)33-79-87
Тюмень (3452)66-21-18
Улан-Удэ (3012)59-97-51
Ульяновск (8422)24-23-59
Уфа (347)229-48-12
Хабаровск (4212)92-98-04
Чебоксары (8352)28-53-07
Челябинск (351)202-03-61
Череповец (8202)49-02-64
Чита (3022)38-34-83
Якутск (4112)23-90-97
Ярославль (4852)69-52-93

Киргизия (996)312-96-26-47

Россия (495)268-04-70

Казахстан (772)734-952-31

<https://goldeneagle.nt-rt.ru> || geo@nt-rt.ru

КАТАЛОГ



STRAIGHT KNIFE

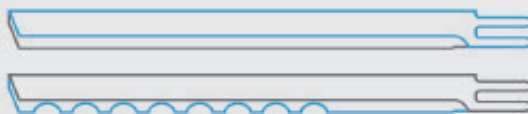



STRAIGHT KNIFE - EASTMAN

伊士曼直刀



4E | 5E | 6E | 7E | 8E | 9E | 10E | 11 1/2E | 12E | 13E | 15E

High Speed Steel 高速鋼 Super Alloy Steel 特殊合金鋼 Alloy Steel 合金鋼



4ET | 5ET | 6ET | 7ET | 8ET | 9ET | 10ET | 11 1/2ET | 12ET | 13ET

High Speed Steel 高速鋼 Super Alloy Steel 特殊合金鋼 Alloy Steel 合金鋼
non-stick coating 不粘塗層



6EW | 7EW | 8EW | 9EW | 10EW | 12EW | 13EW

High Speed Steel 高速鋼 Super Alloy Steel 特殊合金鋼 Alloy Steel 合金鋼
WAVE 波刀



5EWT | 6EWT | 7EWT | 8EWT | 9EWT | 10EWT

High Speed Steel 高速鋼 Super Alloy Steel 特殊合金鋼 Alloy Steel 合金鋼
WAVE 波刀 non-stick coating 不粘塗層



| | | |
|----------------------|--------------------|----------------|
| High Speed Steel 高速鋼 | 643C1-44(5in) | 643C1-41(6in) |
| SLIDER ASSEMBLY 刀鞘 | 643C1-42(7in) | 643C1-43(8in) |
| | 643C1-46(9in) | 643C1-47(10in) |
| | 643C1-53(11-1/2in) | 643C1-45(13in) |

STRAIGHT KNIFE - KM 直刀



4KM(N) | 5KM(N) | 6KM(N) | 6KM | 7KM | 8KM | 9KM | 10KM | 12KM | 13KM | 15KM

High Speed Steel 高速鋼 Super Alloy Steel 特殊合金鋼 Alloy Steel 合金鋼



5KMW | 5KMW(N) | 6KMW | 7KMW | 8KMW | 9KMW | 10KMW

High Speed Steel 高速鋼 Super Alloy Steel 特殊合金鋼 Alloy Steel 合金鋼

WAVE 波刀



High Speed Steel 高速鋼

SLIDER ASSEMBLY 刀鞘

M-086 5" SLIDER-HSS
M-086 6" SLIDER-HSS
M-086 7" SLIDER-HSS
M-086 8" SLIDER-HSS
M-086 9" SLIDER-HSS
M-086 10" SLIDER-HSS
M-086 13" SLIDER-HSS



STRAIGHT KNIFE - COMET 直刀



5C | 6C | 7C | 8C | 9C | 10C | 11C | 12C

High Speed Steel 高速鋼 Super Alloy Steel 特殊合金鋼 Alloy Steel 合金鋼



6CW | 7CW | 8CW | 9CW | 10CW

High Speed Steel 高速鋼 WAVE 波刀

STRAIGHT KNIFE - HITAKA 直刀



4H | 5H | 6H | 7H | 8H | 9H | 10H

High Speed Steel 高速鋼 Super Alloy Steel 特殊合金鋼 Alloy Steel 合金鋼



5HW | 6HW | 7HW | 8HW | 9HW | 10HW

High Speed Steel 高速鋼 Super Alloy Steel 特殊合金鋼 Alloy Steel 合金鋼

WAVE 波刀

STRAIGHT KNIFE - WOLF 直刀



4W | 5W | 6W | 7W | 8W | 9W | 10W | 14W

High Speed Steel 高速鋼 Super Alloy Steel 特殊合金鋼 Alloy Steel 合金鋼



6WW | 7WW | 8WW | 9WW | 10WW

High Speed Steel 高速鋼 Super Alloy Steel 特殊合金鋼 Alloy Steel 合金鋼

WAVE 波刀



STRAIGHT KNIFE - LIGHTING 直刀



6L | 8L | 10L | 12L | 14L

High Speed Steel 高速鋼 Super Alloy Steel 特殊合金鋼

STRAIGHT KNIFE - KURIS 直刀



6K | 7K | 8K | 10K

High Speed Steel 高速鋼



STRAIGHT KNIFE - MAIMIN 直刀



4M | 5M | 6M | 7M | 8M | 5M | 6M | 7M | 8M | 9M | 10M | 11M | 14M

High Speed Steel 高速鋼 Super Alloy Steel 特殊合金鋼 Alloy Steel 合金鋼



6MW | 7MW | 8MW | 9MW | 10MW

High Speed Steel 高速鋼 Super Alloy Steel 特殊合金鋼 Alloy Steel 合金鋼

WAVE 波刀



High Speed Steel 高速鋼

SLIDER ASSEMBLY 刀鞘

6M-SLIDER-HSS
8M-SLIDER-HSS
9M-SLIDER-HSS
10M-SLIDER-HSS
11M-SLIDER-HSS

圓刀
ROUND KNIFE





ROUND KNIFE-BEAVER 圆刀



R2-5/16B(10)
59X10.0X1.00



R5 1/4B
R 5 1/4B55
133X50.8X1.20

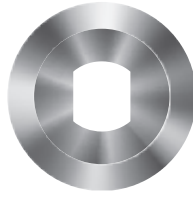

R 6B
152X50.8X1.20

ROUND KNIFE-EASTMAN 伊士曼 圆刀

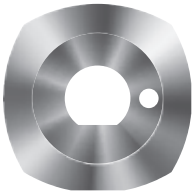

123-HSS
80C1-123
51X16.2X1.05

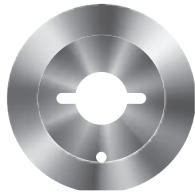

147-HSS
80C1-147
57X16.0X1.10

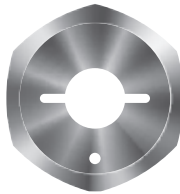

149-HSS
80C1-149
57X16.0X1.05

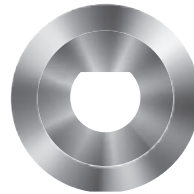

114-HSS
80C1-114
64X22.4X1.00

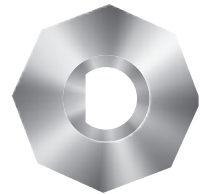

133-HSS
80C1-133
51X16.0X1.20

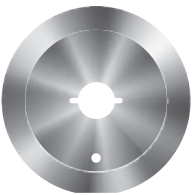

R 4E#141
80C1-141
102X22.2X1.00

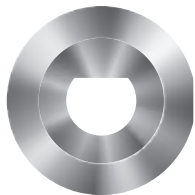

R 4E
80C1-59
102X14.0X1.05

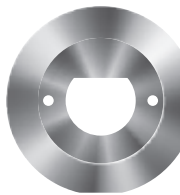

R 5 1/4E
80C1-61
133X52.0X1.05

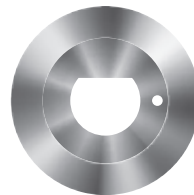

R 5
80C1-101
127X39.6X1.10

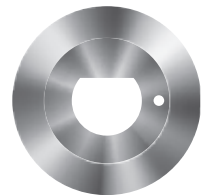

R 6E
80C1-39
152X51.0X1.45



R 7E
178X51.0X1.50

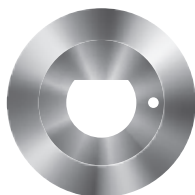

R 7 1/2E
191X51.0X1.90

ROUND KNIFE-HITAKA 圆刀



R 2 1/2H
63X12.2X0.80

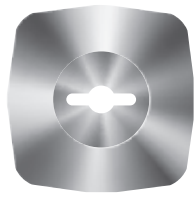

RE-12
66X10.0X1.00

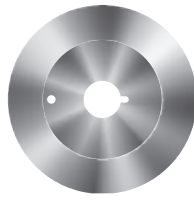

R3 1/2H
89X17.5X0.90



R 5H
127X40.0X1.10

ROUND KNIFE-HOOGS 圆刀



MS-55(7)
115-90
1-MS-55
47X10.0X1.00

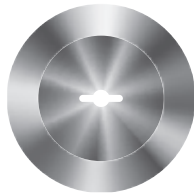

HOOG'S(R)
501-140
1-MS21
110X10.0X1.20

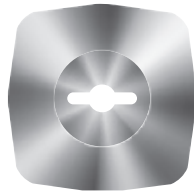

HOOG'S 110m/m
R110-90
3-MS-2
110X10.0X1.60

ROUND KNIFE-KM 圆刀

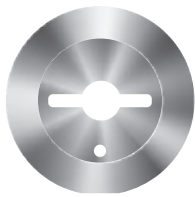

R 2KM
A-113(R)
RS-50
50X10.0X1.25

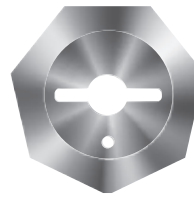

R 2KM(7)
A-113
RS-50(7)
48X10.0X1.05

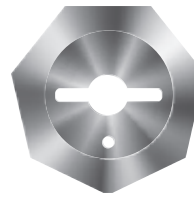

R 2KM(7)-HSS
A-113-HSS
RS-50(7)-HSS
48X10.0X1.05

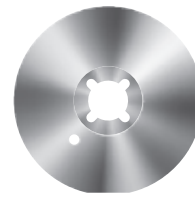

R 4KM
RS-100
100X21.0X1.20

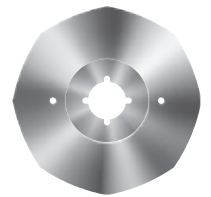

R 4KM(8)
RCS-135(8)
RS-100(8)
100X21.0X1.20



R 5KM-HSS
127X43.0X1.20



R 6KM-HSS
152X50.0X1.50



ROUND KNIFE-KURIS 圆刀

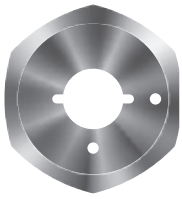

16110(6)
24741(6)
2(6)KURIS
50X16.0X1.00

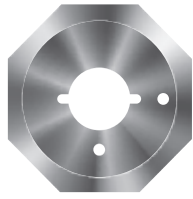

16120(8)
R 2(8)KURIS
50X16.0X1.00

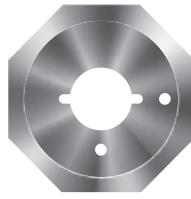

R 2(8)KURIS
50X16.0X1.00

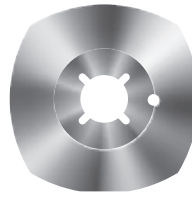

16010(4)
BOM-80(4)
80X16.0X1.00

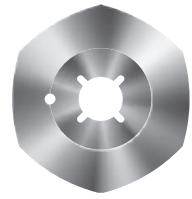

16092(6)
46377(6)
BOM-80(6)
80X22.0X1.00



15710
47014
KRH-10
100X35.0X1.20

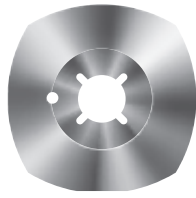

16022(4)
24739(4)
bom-100
BOM-101(4)
100X22.0X1.00

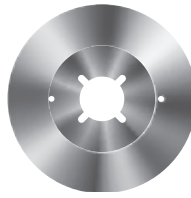

15722
KRH-12
120X35.0X1.20

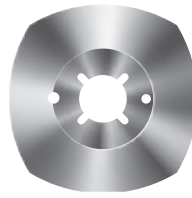

16057(4)
46378(4)
KRH-12(4)
120X35.0X1.50

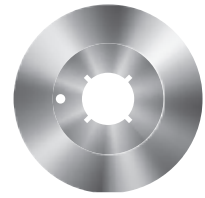

15730
KRH-15
150X35.0X1.50

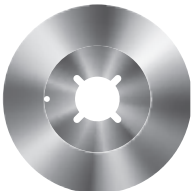

15740
KRH-20
200X40.0X2.20



AS 1026
48X13.0X1.00

ROUND KNIFE-MAIMIN 圆刀

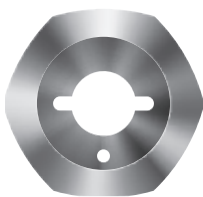

RS-232
50X16.0X1.5



R2 1/2M
64X21.4X0.90

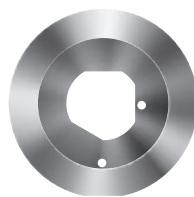

R 4M
102X40.0X1.05

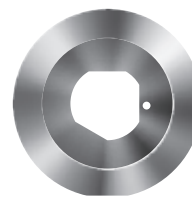

R 5M
127X40.0X1.20

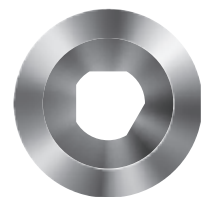

R 5 1/4M
R 5 1/4M59
133X52X1.10



R 6M
152X58.0X1.50

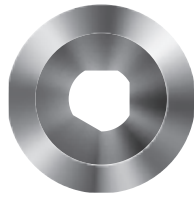

R 7M
178X58.0X1.50

ROUND KNIFE-WOLF 圆刀



1426371
R 2W
PUP
53X17.5X1.01

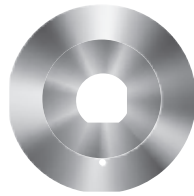

1437070
R 2 1/2W
63X20.5X0.89

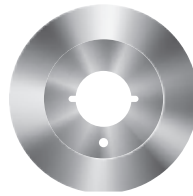

1430770
R 4W
102X31.8X1.04

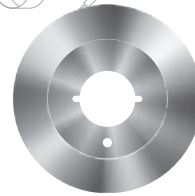

1430370
R 4 3/4W#22
121X42.8X1.10

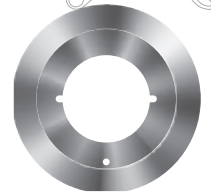

1431170
R 5 1/4W#24
133X50.8X1.04

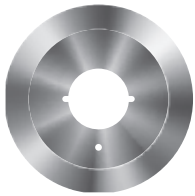

1429970
R 5 1/4W#21
133X42.8X1.00

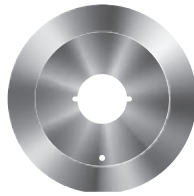

1426970
R 6W NO.16
152X40.1X1.30

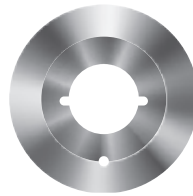

R 6W NO.18
152X50.8X1.30

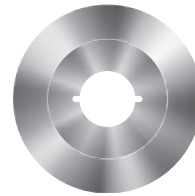

R 7W
178X50.8X1.40

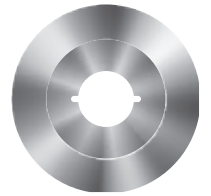

R 8W
203X50.8X1.40



R 10W
254X50.8X1.60



ROUND KNIFE-SUPRENA 圆刀

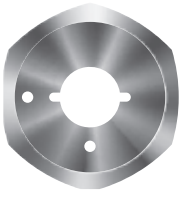

M700(6)
50X16.0X1.00

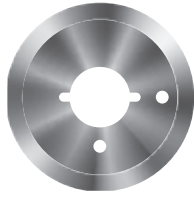

M702
50X16.0X1.00

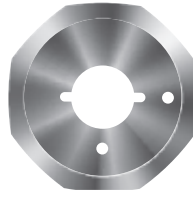

M703(8)
50X16.0X1.00

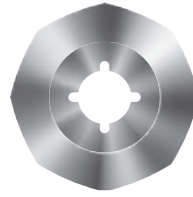

M740(8)
80X22.0X1.00

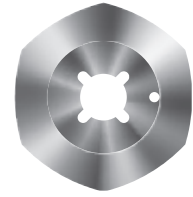

M741(6)
80X22.0X1.00



M742
80X22.0X1.00

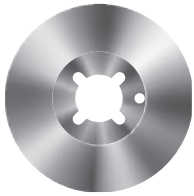

R 1512
100X22.0X1.00

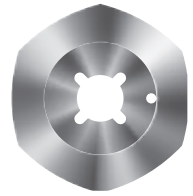

R 1513
100X22.0X1.00

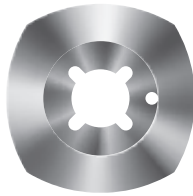

R 1514
100X22.0X1.00

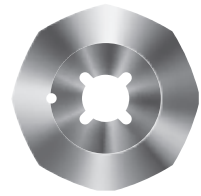

R 1515
100X22.0X1.00

ROUND KNIFE-OTHERS 圆刀



47410
R 28X0.3
28X5.0X0.30



47409
R 45X0.3
45X8.1X0.30



D100
100X22.2X1.05

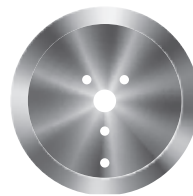

CH141
102X8.0X1.30

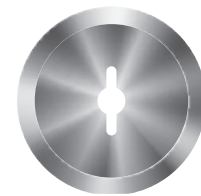

R4 1/4-SKS2
108X10.0X1.20

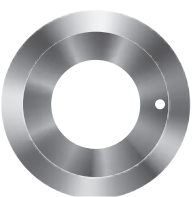

R 80X40X1.0
80X40.0X1.00

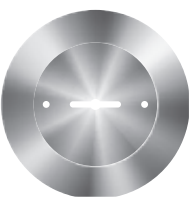

R 4 1/4
108X10.0X1.20

OVERLOCK KNIFE

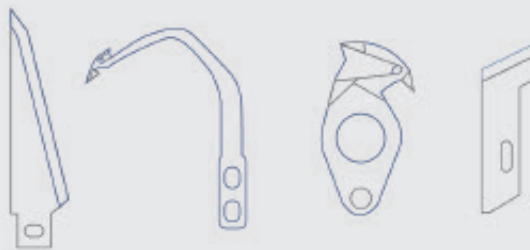

LOWER
UPPER
CT
MOVING
FIXED



OVERLOCK KNIFE for BABYLOCK 拷克刀



205-9101-01A
Upper Knife
BL4-605.SL500



205-9102-01A
Lower Knife(CT)
BL4-605.SL500



405-9101-01A
Upper Knife(CT)
SL-600.700



408-9101-01B
Upper Knife
BL3-408.418. SL800



408-9102-01A
Lower Knife
BL3-408.418. SL800



428-9101-01B
Upper Knife
BL4-428.738



60507
Upper Knife(CT)
L330.L803.SL843



60544
Lower Knife
L330.L803.SL843



PL-Q11-01B
Upper Knife
BL4-736

OVERLOCK KNIFE for BROTHER 兄弟 拷克刀



030-0095-00
BASS3200



030-0096-00
BASS3200



030-0097-00
BASS3200



030-0098-00
BASS3200



030-0461-00
BASS3200



127734-0-01
Upper Knife
B523NL.24NL.25NL



112436-0-01
155193-0-01
Lower Knife
B500,B600



118527-0-01
Lower Knife
B500,B600



140242-0-01
Angled Upper Knife(CT)
B500,B600



144074-0-01
Upper Knife (CT)
B500,B600



144074-300
Upper Knife (CT)
EF4-V41



148198-0-01
Upper knife
B500,B600

OVERLOCK KNIFE for BROTHER 兄弟 拷克刀



148815-0-01
Angled Upper Knife (CT)
B500,B600



S20579-101
Angled Upper Knife (CT)
EF4-V41



S20582-001
Lower Knife
EF4-V41



S20583-001
Lower Knife
EF4-V41



S20896-101
Angled Upper Knife (CT)
EF4-V41



S20897-101
Angled Upper Knife (CT)
EF4-V41



S20898-101
Angled Upper Knife (CT)
EF4-V41



S20899-001
Lower Knife
EF4-V41



X05007001
Lower Knife
B523NL,24NL,25NL

OVERLOCK KNIFE for JUKI 重机 拷克刀



115-65900
Angled Upper Knife(CT)
MO-1516G



115-66502
Lower Knife
MO-1516



118-45609
Upper Knife(CT)
MO-2514



118-45708
Upper Knife(CT)
MO-2516



118-45807
Angled Upper Knife(CT)
MO-2514



118-45906
Angled Upper Knife(CT)
MO-2516



118-46003
Lower Knife
MO-23,24,2500



118-47407
Upper Knife
MO-2314



118-47506
Upper Knife
MO-2316



120-04909
Upper Knife(CT)
MO-2516



124-47504
Lower Knife
MO-3300



131-50503
Upper Knife(CT)
MO-6700



OVERLOCK KNIFE for JUKI 重机 拷克刀



131-50602
Upper Knife(CT)
MO-6700



131-50701
Lower knife(CT)
MO-6700



164-16109
Upper Knife
APW-232



164-18709
Upper Knife
APW-232



611325N
Upper Knife
SJ-611



A4113-102-000
Lower Knife
MO-202,234,305



A4142-335-000
Upper Knife(CT)
MO-202,234,305



A4145-335-000
Lower Knife
MO-202,234,305



B4108-352-000
Upper Knife
MO-352,354,357



B4108-352-00B
Upper Knife
MO-352



B4108-352-00B(L)
Upper Knife
MO-352,354,357



B4108-352-00D
Upper Knife(CT)
MO-352,354,357



B4111-804-00A
Angled Upper Knife(CT)
MO-814



B4111-804-00C
Angled Upper Knife(CT)
MO-816



B4118-804-000
Lower Knife
MO-1000



B4118-804-00C
Lower Knife
MO-800



B4122-352-000
Lower Knife
MO-352



B4122-352-00A
Lower Knife
MO-352



B4122-354-00A
Lower Knife
MO-352,354,357



B4122-357-00D
Lower Knife
MO-352,354,357

OVERLOCK KNIFE for KANSAI-SP 关西 拷克刀



07-124
Upper Knife(CT)
B1702,B2000C



07-168
Upper Knife
WX8103EMK



07-169
Lower Knife
WX8103EMK



07-170
Upper Knife
WX8103EMK



07-206
Lower Knife(CT)
B1702,B2000C



07-406
Upper Knife(CT)
B1702,B2000C



07-505
Upper Knife(CT)
WX8103EMK



07-507
Lower Knife
WX8803EMK



07-558
Lower Knife
RX9903EMK



07-570
Upper Knife(CT)
RX9903EMK



07-702
Upper Knife(CT)
B1702,B2000C



07-703
Upper Knife(CT)
B1702,B2000C



07-707
Lower Knife
B1702,B2000C

OVERLOCK KNIFE for MERROW 梅罗 拷克刀



6-90
Upper Knife
1D,2D,3D,4D,5D



6-91
Lower Knife
1D,2D,3D,4D,5D



6-91E
Lower Knife
1D,2D,3D,4D,5D



6-91F
Lower Knife
1D,2D,3D,4D,5D



A-90-7
Upper Knife
1D,2D,3D,4D,5D



A-90-3
Upper Knife
1D,2D,3D,4D,5D



OVERLOCK KNIFE for MERROW 梅罗 拷克刀



S6-91K
Lower Knife
1D,2D,3D,4D,5D



S6-91H
Lower Knife
1D,2D,3D,4D,5D

OVERLOCK KNIFE for NEW HOME



110-1
ML-110-1
Upper Knife
777,778,779



113
ML-113
Lower Knife
777,778,779



784048
784045001
Lower Knife(CT)
203,234,234D,334



784045
784045008
Upper Knife
203,234,234D,334

OVERLOCK KNIFE for PEGASUS 飞马 拷克刀



3543
Lower Knife
1301,1311



3544A
Upper Knife
1301,1311



137562
Lower Knife
DCM203,204



138559
Upper Knife
DCM203,204



200971
Upper Knife(CT)
DCM204



201121A
Upper Knife(CT)
E Series



201121ANS
Upper Knife(CT)
E Series



201127
Lower Knife
E Series



202295
Lower Knife
L Series



202527
Upper Knife(CT)
L Series



202527A
Upper Knife(CT)
L Series



202570
Upper Knife
R Series

OVERLOCK KNIFE for PEGASUS 飞马 拷克刀



202572
Lower Knife
L Series



202573
Lower Knife
E Series



202893
Lower Knife(CT)
R Series



204161
Lower Knife
L,E Series



204161A
Lower Knife
W664-35



204351
Lower Knife(CT)
E Series



205258
Upper Knife(CT)
R Series



205890
Upper Knife(CT)
R Series



210755(CT)
Angled Upper Knife(CT)
EX5200



211662
Angled Upper Knife(CT)
EX5214H



CT-277000
Upper Knife(CT)
EX Series



277009
Lower Knife
EX Series



2B0010
W2600-35B
W1662-35B



306394
Upper Knife(CT)
W500



312-870-001
Lower Knife
1301,1311



312-870-003
Upper Knife
1301,1311



323-870-005
Upper Knife(CT)
L Series



323-870-200
Upper Knife
R Series



323-870-202
Lower Knife
L Series



323-870-203
Lower Knife
E Series



323-870-207
Upper Knife(CT)
L Series



323-870-210
Lower Knife
L Series



323-870-211
Lower Knife
E Series



323-870-212
Lower Knife(CT)
R Series



OVERLOCK KNIFE for PEGASUS 飞马 拷克刀



323-870-213
Lower Knife
L, E Series



323-870-214
Upper Knife(CT)
E Series



323-870-215
Lower Knife(CT)
R Series



323-870-218
Lower Knife(CT)
E Series

OVERLOCK KNIFE for RIMOLDI 利满地 拷克刀



202142-0-10
Angled Upper Knife
329.529.627.629



202143-0-10
Angled Upper Knife
329.529.627.629



202146-0-10
Lower Knife
329.529.627.629



202932-0-10
Angled Upper Knife
329.529.627.629



203010-0-10
Angled Upper Knife
329.529.627.629



203012-0-10
Lower Knife
329.529.627.629



203066-0-10
Angled Upper Knife
329.529.627.629



203069-0-10
Lower Knife
329.529.627.629



203144-0-10
Lower Knife
329.529.627.629



203759-0-10
Angled Upper Knife
329.529.627.629



203783-0-10
Angled Upper Knife
329.529.627.629



204693-0-10
Lower Knife
329.529.627.629



204693-0-11
Lower Knife
329.529.627.629



207000-2-00
Angled Upper Knife(CT)
329.529.627.629



207001-2-00
Angled Upper Knife(CT)
329.529.627.629



207002-2-00
Angled Upper Knife(CT)
329.529.627.629



207003-2-00
Angled Upper Knife(CT)
329.529.627.629



207004-2-00
Angled Upper Knife(CT)
329.529.627.629

OVERLOCK KNIFE for RIMOLDI 利满地 拷克刀



207006-2-00
Angled Upper Knife(CT)
329.529.627.629



207015-2-00
Lower Knife(CT)
329.529.627.629



207016-2-00
Lower Knife(CT)
329.529.627.629



207017-2-00
Lower Knife(CT)
329.529.627.629



207020-2-00
Lower Knife(CT)
329.529.627.629



207020-2-01
Lower Knife(CT)
329.529.627.629



270-112
Angled Upper Knife
329.529.627.629



270-112/1
Angled Upper Knife
329.529.627.629



270-113
Lower Knife
627



270-113/1
Lower Knife
329.529.627.629



2701P9-113/1
Lower Knife
329.529.627.629



276B-112
Angled Upper Knife
329.529.627.629



277-112
Angled Upper Knife
329.529.627.629



277-113
Lower Knife
329.529.627.629



2777-112
Angled Upper Knife
329.529.627.629



2777-1121
Angled Upper Knife
329.529.627.629



279-112
Angled Upper Knife
329.529.627.629



279-113/1
Lower Knife
329.529.627.629



290-112
Angled Upper Knife
329.529.627.629



290-113
Lower Knife
329.529.627.629



290-113SP
Angled Upper Knife
329.529.627.629



302807-0-10
Upper Knife
261.2.3.4.5



302808-0-10
Lower Knife
261.2.3.4.5



6378-112
Upper Knife
261.2.3.4.5



OVERLOCK KNIFE for RIMOLDI 利满地 拷克刀



6378-113
Lower Knife
261.2.3.4.5



CT270-112
Angled Upper Knife(CT)
329.529.627.629



CT270-113/1
Lower Knife(CT)
329.529.627.629



CT276B-112
Angled Upper Knife(CT)
329.529.627.629



CT277-112
Angled Upper Knife(CT)
329.529.627.629



CT277-113
Lower Knife(CT)
329.529.627.629



CT2777-112
Angled Upper Knife(CT)
329.529.627.629



CT2777-1121
Angled Upper Knife(CT)
329.529.627.629



CT279-112
Angled Upper Knife(CT)
329.529.627.629



CT279-113/1
Lower Knife(CT)
329.529.627.629



CT290-112
Angled Upper Knife(CT)
329.529.627.629



CT290-113
Lower Knife(CT)
329.529.627.629



CT290-113SP
Lower Knife(CT)
329.529.627.629



CT302865-0-11
Upper Knife(CT)
261.2.3.4.5

OVERLOCK KNIFE for SINGER 胜家 拷克刀



42305
Upper Knife
81.81K.81V



42309
Lower Knife
81.81K.81V



164037
Lower Knife
246K.460K.992B



164233
Lower Knife
246K.460K.992B



164308
Angled Upper Knife
246K.460K



164550
Angled Upper Knife
246K.460K

OVERLOCK KNIFE for SINGER 胜家 拷克刀



164556
Angled Upper Knife
246K,460K



164728
Lower Knife
246K,460K,992B



164809
Lower Knife(CT)
246K,460K,992B



164813
Lower Knife(CT)
246K,460K,992B



410295
Lower Knife
U12,U32,U52,U53



412544
Lower Knife(CT)
U12,U32,U52



412585
Lower Knife(CT)
U12,U32,U52



412749
Lower Knife
U12,U32,U52,U53



CT164728
Lower Knife(CT)
246K,460K,992B

OVERLOCK KNIFE for SIRUBA 银箭 拷克刀



B
Lower Knife
737,747,757



KR-23
Upper Knife(CT)
737,747,757



KR-23A
Upper Knife(CT)
737,747,757



KR-23C
Lower Knife(CT)
757E



KR-35
Lower Knife
737,747,757



KR-35C
Lower Knife
757E

OVERLOCK KNIFE for TOYOTA 丰田 拷克刀



1250004-229B
Upper Knife
6300,6600



1250004-237B
Lower Knife
6300,6600



1250014-229
Upper Knife(CT)
6300,6600



1270004-229
Upper Knife(CT)
6300,6600



1650004-229
Upper Knife(CT)
6300,6600



OVERLOCK KNIFE for TOYOTA 丰田 拷克刀



5140008-413
Fixed Knife
EK1



5150002-321
Needle Guard
EK1



5150002-323
Needle Guard
EK1



5150002-324
Needle Guard
EK1



5150007-311
Upper Knife(CT)
EM1



5150007-321
Lower Knife
EK1



5140008-413
Movable Knife
EK1

OVERLOCK KNIFE for UNION-SP 友联 拷克刀



28964
Upper Knife
36200



36250
Lower Knife
36200



36270
Upper Knife
36200



39549
Lower Knife
39500



39570
Angled Upper Knife
39500



39270A
Upper Knife
36200



39549J
Lower Knife
39500



39549N
Lower Knife(CT)
39500



39570J
Angled Upper Knife
39500



39570K
Angled Upper Knife
39500



CT39549
Lower Knife(CT)
39500



CT39549J
Lower Knife(CT)
39500

OVERLOCK KNIFE for UNION-SP 友联 拷克刀



CT39570

Angled Upper Knife(CT)
39500



CT39570J

Angled Upper Knife(CT)
39500

OVERLOCK KNIFE for YAMATO 大和 拷克刀



20491

Angled Upper Knife(CT)
Z1000



20493

Upper Knife
Z1000



20496

Upper Knife(CT)
Z6000.Z8000



2100167

Lower Knife
Z6000.Z8000



2101155

Fixed Knife(CT)
K1.AZ8500



2101156

Moving Knife(CT)
K1.AZ8500

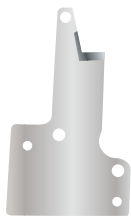

2111055

Lower Knife
AZ-8000 (K2)



2111056

Upper Knife
AZ-8000 (K2)



2114012

Movable Cutting Knife
MC.AZ8500



2114013

Fixed Cutting Knife
MC.AZ8500



2121111

Lower Knife
AZX-8600



22195

Lower Knife
Z1000



30421

Lower Knife
DCY.DCZ



32914

Upper Knife(CT)
DCY.DCZ



35285

Lower Knife
DCY.DCZ



35286

Angled Upper Knife(CT)
DCY.DCZ



37469

Upper Knife
DCY-104



37469-HSS
Lower Knife
DCY-104



OVERLOCK KNIFE for YAMATO 大和 拷克刀



37472-HSS
Upper Knife
DCY-104



37472
Lower Knife
DCY-104



37514
Upper Knife
DCY,DCZ



37538
Lower Knife
DCY,DCZ



6200022
Upper Knife(CT)
YAMATO



6200097
Lower Knife
YAMATO



6200308 (2150256)
Upper Knife(CT)
AZ8500



95276
Upper Knife(CT)
VC3800,VC2700



95277
Lower Knife
DW-1200,1400

OVERLOCK KNIFE for OTHERS 其他 拷克刀



0246002553
Top Knife
DURKOPP 745,749



0746060689
Upper Cutting Knife R
DURKOPP 746,748



0746060691
Upper Cutting Knife R
DURKOPP 746,748



0746060692
Upper Cutting Knife L
DURKOPP 746,748



21-5602
Top Knife
L.C.A./EAGLE



300417
Lower knife(CT)
HL603A,604,794



DSK-25
Lower knife Side
Cutter



DSK-27
Upper knife Side
Cutter



11442
Lower knife (CT)
300,340,340D



X05007001
Lower knife
M435,M435C,M530



127734001
Upper Knife
M435,M435C,M530



755106
Upper Knife



755128
Lower knife



RL-SL-261416

LOWER KNIFE for ROUND KNIFE 圆刀下刀



261416-2
R4 1/4-CT(2)
2615
Lower Knife
35X9.6



R4 1/4-CT(2-2)
Lower Knife
34.7X9.6



R4 1/4-CT
Lower Knife
34.7X9.6



A-114
RS-50-CT
Lower Knife



ACE(Upper)
08-282
471
Strip Cutter



ACE(Lower)
08-281
470
Strip Cutter



TRIMMING KNIFE



LOWER
UPPER
CT
MOVING
FIXED

TRIMMING KNIVES for ADLER 切线刀



129-17-185-3
91-171853-05
Counter knife [1296](#)

TRIMMING KNIVES for BROTHER 兄弟 切线刀



105306-101
Thread Cutter Plate
[B925](#)



105307-101
Thread Cutter
[B925](#)



140888-001
Thread Cutter
[B500](#)



141509-101
141509-001
Upper Thread Trimming
Ass. [B814](#)

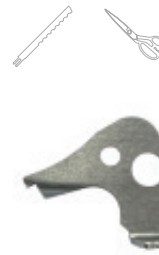

141512-001
Upper Thread
Middle Blade [B814](#)



141513-001
Upper Thread Upper
Blade [B814](#)



141541-0-01
Moving Knife
[B814.B815](#)



141543-0-01
Fixed Knife
[B814.B815](#)



152897-0-01
Knife Conn. Rod
[B430](#)



152901-0-01
Moving Knife
[B430](#)



152905-0-01
Fixed Knife
[B430](#)



152906-0-01
Thread Retainer
[B430](#)



152981-0-01
Knife Arm
[B430](#)



153020-001
Fixed Knife
[BAS-610](#)



154568-001
Fixed Knife
[716-400](#)



159274-001
Moving Knife
[LH4-B815](#)



159276-201
Fixed Knife
[LH4-B815](#)



159540-001
Moving Knife
[LH4-B791-430](#)



TRIMMING KNIVES for BROTHER 兄弟 切线刀



159541-001
Fixed Knife
LH4-B791-430



S02374-001
Fixed Knife
BAS-326



S02375-001
Moving Knife
BAS-326



S02637-001
Fixed Knife
B737



S02643-001
Moving Knife
B737



S02645-001
Moving Knife
B737



S02646-001
Moving Knife
S-7200A



S03627-001
Fixed Knife
B917



S03629-001
Moving Knife
B917



S07526-001
Moving Knife
B842.875



S07526-201
Moving Knife
B842.875



S07527-001
Fixed Knife
B842.875



S08302-001
Comer Knife (S-Left)
BAS-610.1.3A



S08322-001
Comer Knife (S-Right)
BAS-610.1.3A



S09075-001
Lower knife
FD4-B270



S09093-001
Upper knife(CT)
FD4-B270



S09094-001
Upper knife(CT)
FD4-B270



S09101-001
Lower knife
FD4-B270



S10205-001
Moving Knife
BAS-311A



S10210-101
Knife
BAS-311A



S10210-101
Knife
BAS-311A



S10210-201
Fixed Knife
B430E



S16248-001
Top Knife
BAS-610



S19824-001
Needle Thread Trimming
Ass. LH4-815

TRIMMING KNIVES for BROTHER 兄弟 切线刀



S20118-001
Trimming Knife
V-41



S28348-001
Upper Knife Left(CT)
FD3-B256



S28352-001
Lower Knife
FD3-B256



S28650-201
Lower Knife
FD3-B256



S28654-001
Upper Knife
FD3-B256



S34895-001
Fixed Knife
RH-9820



S34899-001
Movable Knife Assy
RH-9820



S35029-001
Upper Movable Knife A
RH-981A



S35437-101
Buttonhole Knife
981



S37671-101
Moving Knife L L3
RH-981A



S37672-101
Moving Knife L L4
RH-981A

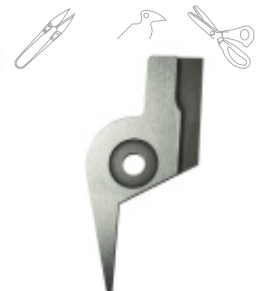

S37675-101
Moving Knife L L3
RH-981A



S37676-101
Movable Knife R L1
RH-981A



S37723-001
Moving Knife
981



S49988-001
Movable Knife
BAS-016B



S50113-101
Upper Thread Trimmer
HE-800



S50258-101
Lower Thread Retainer
HE-800A



S50259-101
Lower Thread Retainer
HE-800A



S50260-101
Lower Fixed knife
HE-800A



S50263-001
Moving Knife
HE-800A



S50265-001
Lower Thread Clamp Plate
HE-800A



S50270-000
Lower Thread Presser
HE-800A



S50404-101
Upper Thread Trimmer Assy
HE-800A



S56370-001
Moving Knife(Lower)
HM8180



TRIMMING KNIVES for BROTHER 兄弟 切线刀



S56917-001
Fixed Knife (Lower)
HM-8180



SB1189-001
Movable Knife F Assy
KE-430F



SB1191-101
Fixed Knife F Assy
KE-430F



SA3330-001
Moving Cutting Knife
KE430D



SA3335-001
Fixed Cutting Knife
KE430D



SA3656-101
Moving Cutting Knife
KE430D



SA3658-001
Fixed Cutting Knife
KE430D



SA6596-001
Movable Knife Set F-SCS
KE-430D



SA6597-001
Fixed Knife Set F-SC
KE-430D



SA6988-001
Movable Knife R
RH-9820



SA6989-001
Movable Knife L
RH-9820



THREAD-260
Thread Cutter
B755



THREAD-755
Thread Cutter
B831

TRIMMING KNIVES for JUKI 重机 切线刀



100-01709
Take-Up Thread Cutter
LZ-2280



102-11100
Moving Knife
LH-1162



102-11209
Fixed Knife
LH-1162



102-11605
Moving Knife
LH-3168



107-26305
Moving Knife
LU-2216N-7



110-40052
Moving Knife
DDL-5550H

TRIMMING KNIVES for JUKI

重机 切线刀



110-40201

[DDL-5550H](#)



110-42652

[DDL-5550NH](#)



110-93259

Moving Knife
[DDL-5550-H-6](#)



110-95403

Knife Thread Guide
[DDL-5550N-7](#)



113-13053

Moving Knife
[DLN-5410-6](#)



113-51400

Moving Knife
[DU-141-5](#)



113-51509

Fixed Knife
[DU-141-5](#)



114-09257

Moving Knife
[DDL-5550H-6](#)



114-09604

Fixed Knife
[DDL-5550H-6](#)



124-19602

Chain Cutter Knife
[MO-3300](#)



129-22704

Chain Cutter
[MS-1190,1260](#)



131-16702

Chain Cutter
[MO-6700](#)



137-31161

Needle Thread Trimmer
[LBH-790,1700](#)



137-35469

Trimmer, Upper Asm.
[LBH-1790](#)



137-35956

Trimmer, Upper Asm.
[LBH-790,1700](#)



137-36103

Tension Spring
[LBH-790,1700](#)



137-35451

Trimmer, Lower Asm.
[LBH-790,1700](#)



140-41206

Buttonhole Knife
[3200 38mm](#)



164-03008 (1.0)

[APW-192/195](#)



16409906

[APW-895](#)



166-07301

Corner Knife H.S.S. (A-1)
[APW-192](#)



166-07400

Corner Knife H.S.S. (A-2)
[APW-192](#)



166-07509

Corner Knife H.S.S. (B-1)
[APW-192](#)



166-07608

Corner Knife H.S.S. (B-2)
[APW-192](#)



TRIMMING KNIVES for JUKI 重机 切线刀



166-07707
Corner Knife H.S.S. (C-1)
APW-192



166-07806
Corner Knife H.S.S. (C-2)
APW-192



226-55302
Fixed Knife
LH-3168



235-06009
Cloth Cutting Knife
LZ-2280N



235-06108
Throat Plate Knife
LZ-2280N



303-65407
Fixed Knife
MFC-7605



305-00300
Moving Knife
MFC-7605



320-16107
Lower Thread Cutter Knife
MEB-3200



320-18012
Moving Knife
MEB-3200



320-18509
Fixed Knife
MEB-3200



320-20505
Thread Cutter Lower Knife
MEB-3200



320-20604
Thread Cutter Upper Knife
MEB-3200



320-20703
Thread Cutter Upper Knife
MEB-3200



320-20919
Thread Cutter Upper Knife
MEB-3200



320-23210
Thread Cutter Upper Knife
MEB-3200



320-23319
Thread Cutter Knife
MEB-3200

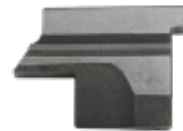

32063208(16m/m)
Thread Cutter Knife
MEB-3200



32063109(18m/m)
Thread Cutter Knife
MEB-3200



32063000(20m/m)
Thread Cutter Knife
MEB-3200



34749A
Upper Knife
MFC-7700, MF7000



34770AH
Lower Knife
MFC-7700, MF7000



40026155
DDL-9000A/B



40050589
DDL-9000A/B



40089755
DDL-8700J-7

TRIMMING KNIVES for JUKI 重机 切线刀



400-04255
Needle Thread Trimming Ass.
LBH-1790



400-04311
BT. Trimmer
LBH-1790



400-12403
Driving Knife
LH-3528-7



400-12404
Fixed Knife
LH-3528-7



400-15996
Thread Cutter Upper Knife
MEB-3200



400-38091
Fixed Knife
MF-7700



400-38754
Moving Knife
MF-7700



400-39364
Moving Knife
MF-7800



400-42378
Fixed Knife
MF-7800

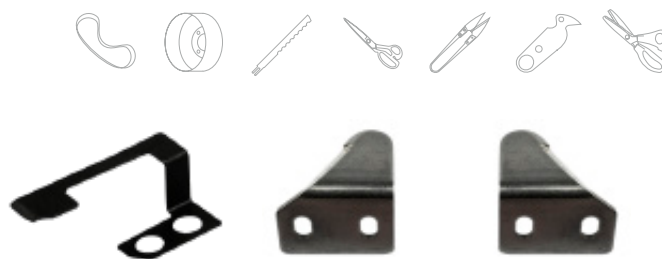

400-76709
LH-3528-7



B1130-026-000
Trimming Blade
MS-261



B1131-026-000
Trimming Blade
MS-261



B1528-380-OAO
MH-380



B1528-804-000A
Chain Cutter Knife
MO-2500



B1528-804-000
Chain Cutter Knife
MO-2500



B1530-352-000
Thread Cutter
MO-352,357



B2001-761-OAO
Needle Thread Trimming Ass.
LBH-761



B2001-762-OAO
Needle Thread Trimming Ass.
LBH-762



B-2001-771-OAO
Needle Thread Trimming Ass.
LBH-771



B-2002-761-OAO
Upper Thread Trimming Blade
LBH-761



B-2002-771-OAO
Upper Thread Trimming Blade
LBH-771



B2003-761-000
Needle Thread Tension Spring
LBH-761



B2003-771-000
Needle Thread Tension Spring
LBH-771



B2406-373-OAO
Moving Knife
MB-373



TRIMMING KNIVES for JUKI 重机 切线刀



B2406-761-OAO
Counter Knife
LBH-761



B2406-771-OAO
Counter Knife
LBH-761



B2408-761-000
Counter Knife
LBH-761



B2408-771-000
Counter Knife
LBH-761



B2410-373-000
Fixed Knife
MB-373



B-2421-205-OAO
Moving Knife
AMS-210



B-2421-210-000
Moving Knife
AMS-210



B2421-210-AAO
Moving Knife
AMS-212



B2424-210-000
Fixed Knife
AMS-210



B2424-210-AOO
Fixed Knife
AMS-212



B2421-280-OAO
Moving Knife
Lk-280,980,1850



B2421-280-000
Moving Knife
Lk-280,980,1850



B2424-280-000
Fixed Knife
Lk-280,980,1850



D2402-555-BAO
Moving Knife
DDL-555-2.3.4.5



D2406-555-B00
Fixed Knife
DDL-555-2.3.4.5



D2406-555-DOH
Fixed Knife
DDL-5550H



D2423-141-EOO
Moving Knife
DU-141-5



D2424-141-EOO
Fixed Knife
DU-141-5



MAS-11012000
Upper Knife, Left
MFB-860,2600



MAS-11013000
Upper Knife, Right
MFB-860,2600



MAS-11016000
Lower Knife, Left
MFB-860,2600



MAS-11017000
Lower Knife, Right
MFB-860,2600

TRIMMING KNIVES for MITSUBISHI 三菱 切线刀



MF00A0834
Moving Knife
LS2-180



MF00A0838
Fixed Knife
LS2-180



MF02A0834
Moving Knife
LS2-180



MS03A0838
Fixed Knife
PLK-1006



MF40A2835
Right Knife
DB-189



MF40A1835
Right Knife
DB-189



MF40A1834
Left Knife
DB-189

TRIMMING KNIVES for NEW LONG 纽朗 切线刀



246061
Moving Knife
NP-7



246071
Fixed Knife
NP-7



A-121-1
Thread Cutter
1D,2D,3D,4D,5D

TRIMMING KNIVES for PEGASUS 飞马 切线刀



201308P
Chain Cutter knife
E Series



202451
Chain Cutter knife
DCM



236606
Upper Knife
FS.FV.FW Series



236608
Lower Knife
FS.FV.FW Series



257573
Upper knife(CT)
W664-05



257573A
Upper knife(CT)
W664-33B



TRIMMING KNIVES for PEGASUS 飞马 切线刀



257574
Upper Knife(CT)
W664-35



323-873-001
Chain Cutter Knife
E Series



323-873-200
Chain Cutter Knife
DCM



350018-91
Fixed Cutting Knife
W762/UT



350024
Moving Cutting Knife
W762/UT



350218
Moving Knife
W664



350220
Fixed Knife
W664

TRIMMING KNIVES for PFAFF 百福 切线刀



91-171853-05
Counter Knife
480

TRIMMING KNIVES for REECE 利是 切线刀



10-4600-0-000
Upper Thread Trimming
101



32-2047-1-001
Left Knife
32.46.47.48



32-2047-1-002
Right Knife
32.46.47.48



32-2048-1-001
Left Knife
32.46.47.48



32-2048-1-002
Left Knife
32.46.47.48



40-0012-1-045
Center Knife
31.32.42.46.47

TRIMMING KNIVES for REECE 利是 切线刀



40-0012-2-045
Center Knife
[31.32.42.46.47](#)



40-0127-1-000
Tab Knife
[31.32.42.46.47](#)



40-0127-2-000
Tab Knife
[31.32.42.46.47](#)



42-0012-0-045
Center Knife
[31.32.42.46.47](#)



48-1125-5-721
Top Knife
[32.46.47.48](#)

TRIMMING KNIVES for RIMOLDI 利满地 切线刀



202194-0-10
Thread Cutter Knife
[329.629](#)



270-188
Thread Cutter Knife
[329.629](#)

TRIMMING KNIVES for SINGER 胜家 切线刀



164861
Chain Cutter Knife
[246K.460K](#)



414029
Stationary Knife
[591B.D.E](#)



414030
Underbed Trimmer
[491D.591D.601D](#)



55459
Shuttle Thread Knife
[269W.270](#)



540741
Underbed Trimmer
[491D.591D.601D](#)



540760
Stationary Knife
[491D200](#)

TRIMMING KNIVES for SIRUBA 银箭 切线刀



A702
Trimming Blade
[AA](#)



A703
Trimming Blade
[AA](#)



BK-10F
Fixed Knife
[747.757](#)



CRL03
Upper knife(CT)
[C007E/CRL](#)



CR26J
Fixed Knife(CT)
[F007](#)



CR26H
Fixed Knife(CT)
[C007E/CRL](#)



TRIMMING KNIVES for SIRUBA 银箭 切线刀



CRL03H
Fixed Knife(CT)
[C007E/CRL](#)



CRL03J
Fixed Knife(CT)
[C007E/CRL](#)



CRL09J
Lower Knife
[C007J](#)



FBQ30
Lower knife(CT)
[F007E/FBQ](#)



FR34
Fixed Knife(CT)
[F007/FBQ](#)



FR34B
Upper Knife(CT)
[F007E/FBQ](#)



FR40
Lower knife(CT)
[F007E/FBQ](#)



FR40J
Lower knife
[F007](#)



FR40D
Lower knife(CT)
[F007E/FB\(D\)](#)



FR134
Upper knife(CT)
[F007](#)



LU02
Moving Knife
[L818F](#)



LU05
Fixed Knife
[L818F](#)



LU101
Movable Cutting Knife



LU103
Fixed Cutting Knife



LU501
Movable Cutting Knife



LU503
Fixed Cutting Knife



LU602
Moving Knife



LU605
Fixed Knife



KS-24
Chain Cutter knife
[737.747.757](#)



UT506
Fixed Knife
[C007/UTR1](#)



UT507
Moving Knife
[C007/UTR1](#)

TRIMMING KNIVES for SUNSTAR 日星 切线刀



10-001A-2700
Fixed Knife
KM-250



10-101A-2700
Fixed Knife
KM-250



10-001A-64L7
Fixed Knife
KM-640



10-005A-2700
Fixed Knife
KM-250



10-006A-235B
Fixed Knife
KM-250



10-106A-2700
Fixed Knife
KM-250

TRIMMING KNIVES for TAJIMA 田岛 切线刀



AT0204000000
Moving Knife



EG0204000000
Fixed Knife



FX0227000000
Moving Knife



FX0228000000
Fixed Knife



TRIMMING KNIVES for TOYOTA 丰田 切线刀



2111407-553B
Moving Knife
AD-158



2111417-556B
Fixed Knife
AD-158



TRIMMING KNIVES for YAMATO 大和 切线刀



20271
Chain Cutter Knife
[AZ-8000](#)



68121
Lower Knife
[FD-62](#)



68184
Upper Knife
[FD-62](#)



82012
Cutting Knife
[CM251.351](#)



94411
Moving Knife
[DV,DW-1200,1400](#)



94417
Fixed Knife
[DV,DW-1200,1400](#)



95399
Knife



3021109
Lower Knife
[FD-62-12](#)



3021111
Upper Knife
[FD-62-12](#)



3100512
Fixed Knife
[VC Series](#)



3100513
Moving Knife
[VC Series](#)



3100708
Movable Trimming Knife
[VC-2700](#)



3101026
Lower Knife
[VC-2685](#)



3101028
Upper Knife(CT)
[VC-2685](#)



3101465
Upper Knife(CT)
[VC-2629](#)



3101633
Lower Knife
[VC3800,VE2700](#)



3101699
Lower Knife
[VC2700](#)



3101700
Upper Knife
[VC-2700](#)



3101801
Moving Knife
[VC-2700](#)



3101802
Fixed Knife
[VC-2700](#)



3110037
Upper Knife(CT)
[VC-3611](#)



3110038
Lower Knife
[VC-3611](#)



3021060
Knife
[FD62-01](#)



3021061
Knife
[FD62-01](#)

TRIMMING KNIVES for YAMATO 大和 切线刀



3201062
Lower Knife
VC3800,VC2700



3501032
Angled Upper(CT)
VC-2700



3501535
Angled Upper(CT)
VG-3721



3501026
Lower Knife
VG2735



3501597
Angled Upper(CT)
VG-3721

TRIMMING KNIVES for UNION-SP 友聯



35796B
Upper Chain Cutter
35800



35796C
Lower Chain Cutter
35800



34749EL
Knife
MFC-7605U-H21





钮门刀
BUTTON HOLE KNIFE

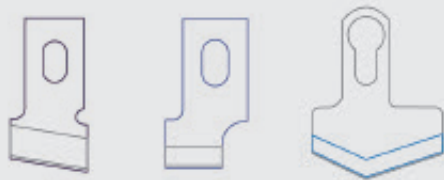

BUTTONHOLE KNIVES for SINGER, JUKI, REECE, BROTHER 胜家 重机 利是 兄弟 钮门刀



71CL 1/4
Buttonhole Knife
71 Class



71CL 5/16
Buttonhole Knife
71 Class



71CL 3/8
Buttonhole Knife
71 Class



71CL 7/16
Buttonhole Knife
71 Class



71CL 1/2
Buttonhole Knife
71 Class



71CL 9/16
Buttonhole Knife
71 Class



71CL 5/8
Buttonhole Knife
71 Class



71CL 11/16
Buttonhole Knife
71 Class



71CL 3/4
Buttonhole Knife
71 Class



71CL 7/8
Buttonhole Knife
71 Class

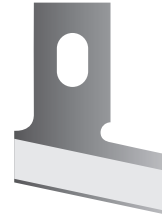

71CL 1
Buttonhole Knife
71 Class

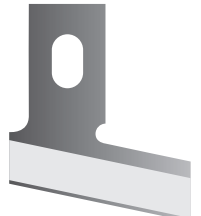

71CL 1 1/8
Buttonhole Knife
71 Class

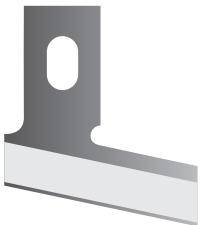

71CL 1 1/4
Buttonhole Knife
71 Class



71CL 1 3/8
Buttonhole Knife
71 Class



71-90 3/8
Buttonhole Knife
71-90 Class



71-90 7/16
Buttonhole Knife
71-90 Class



71-90 1/2
Buttonhole Knife
71-90 Class



71-90 9/16
Buttonhole Knife
71-90 Class



71-90 5/8
Buttonhole Knife
71-90 Class



71-90 3/4
Buttonhole Knife
71-90 Class



71-90 7/8
Buttonhole Knife
71-90 Class



71-90 1
Buttonhole Knife
71-90 Class



BUTTONHOLE KNIVES for SINGER, JUKI, REECE, BROTHER 胜家 重机 利是 兄弟 钮门刀



S356N 1/8
Buttonhole Knife
S356N Class



S356N 1/4
Buttonhole Knife
S356N Class



S356N 5/16
Buttonhole Knife
S356N Class



S356N 3/8
Buttonhole Knife
S356N Class



S356N 7/16
Buttonhole Knife
S356N Class



S356N 1/2
Buttonhole Knife
S356N Class



S356N 9/16
Buttonhole Knife
S356N Class



S356N 5/8
Buttonhole Knife
S356N Class



S356N 11/16
Buttonhole Knife
S356N Class



S356N 3/4
Buttonhole Knife
S356N Class



S356N 7/8
Buttonhole Knife
S356N Class



S356N 1
Buttonhole Knife
S356N Class



S356N 1 1/8
Buttonhole Knife
S356N Class



S356N 1 1/4
Buttonhole Knife
S356N Class



S356N 1 3/8
Buttonhole Knife
S356N Class



10-3072-0-014
Knife W
Regular Eye 101



10-3072-0-024
Knife W
Regular Eye 101



17-0064-5-864(CA)
Cutting Knife W
Regular Eye 100



C72 11/4RJ-RE
Knife W
Regular Eye 101

BUTTONHOLE KNIVES & NEEDLE PLATE for BROTHER 兄弟 钮门刀



S10570-001 1/8
Needle Plate
1/8" B777



S10572-001 3/16
Needle Plate
3/16" B777



S10573-001 1/4
Needle Plate
1/4" B777



S10605-001
Counter Knife
B777

BUTTONHOLE KNIVES & NEEDLE PLATE for JUKI 重机 钮门刀



B1190-522-SOO
Needle Plate
1/8" DLM-522



B1190-522-TOO
Needle Plate
3/16" DLM-522



B1190-522-UOO
Needle Plate
1/4" DLM-522



B1190-522-VOO
Needle Plate
3/8" DLM-522



B1190-522-XOO
Needle Plate
3/32" DLM-522



B1190-522-YOB
Needle Plate
DLM-522



B4121-052-AOO
Counter Knife
DMN-522



B4121-522-000
Counter Knife
DMN-522



B4121-522-000-L
Counter Knife
DMN-522



B4145-530-BOO
Counter Knife
DMN-530



包边
BINDER

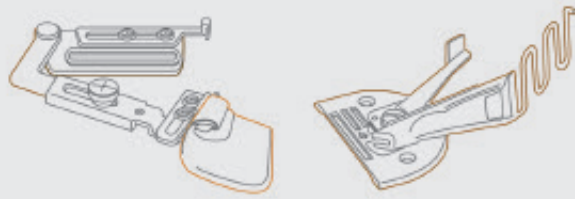

BINDERS & HEMMER FEET for UNION-SP 35800 于仁埋夹筒

23420Z-9 for UNION-SP 35800 MACHINES



23420Z-9 1/8MH
23420Z-9 1/8H
23420Z-9 1/8XH

Double Lap Seam Folder

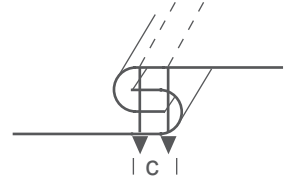

A4 / 100 for SINGLE NEEDLE LOCKSTITCH MACHINES 散口包边筒



Tape Size

| Tape Size | Finished Size |
|-----------|---------------|
| 3/8" | 3/16" |
| 1/2" | 1/4" |
| 5/8" | 5/16" |
| 3/4" | 3/8" |
| 7/8" | 7/16" |
| 1" | 1/2" |
| 1 1/8" | 9/16" |
| 1 1/4" | 5/8" |

Braid or Tape Binder

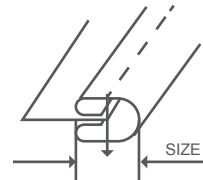

A9 / 508 for SINGLE NEEDLE LOCKSTITCH MACHINES 曲咀包边筒



Tape Size

| | |
|--------|--------|
| 5/8" | 1 1/2" |
| 3/4" | 1 5/8" |
| 7/8" | 1 3/4" |
| 1" | 1 7/8" |
| 1 1/8" | 2" |
| 1 1/4" | |

Plain Bias Binder

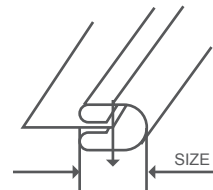

A10 / S60 for SINGLE NEEDLE LOCKSTITCH MACHINES 平车直角包边器



| Tape Size | Fin. | Tape Size | Fin. |
|-----------|------|-----------|----------|
| 5/8" | 16 | 4 | 1 1/4" |
| 11/16" | 18 | 4.5 | 1 19/32" |
| 13/16" | 20 | 5 | 1 3/8" |
| 7/8" | 22 | 5.5 | 1 1/2" |
| 15/16" | 24 | 6 | 1 5/8" |
| 1" | 26 | 6.5 | 1 3/4" |
| 1 1/8" | 28 | 7 | 2" |
| 1 3/16" | 30 | 8 | |
| | | mm | mm |

Right Angle Bias Binder

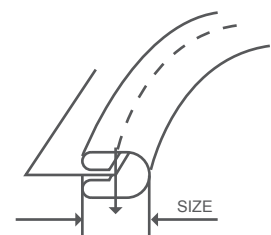



A11 / S72L for SINGLE NEEDLE LOCKSTITCH MACHINES 拉脚筒



Tape Size

| | | | |
|--------|------|---------|------|
| 1/8" | 3mm | 13/16" | 20mm |
| 3/16" | 5mm | 7/8" | 22mm |
| 1/4" | 6mm | 1" | 25mm |
| 5/16" | 8mm | 1 1/8" | 28mm |
| 3/8" | 10mm | 1 3/16" | 30mm |
| 1/2" | 13mm | 1 1/4" | 32mm |
| 19/32" | 15mm | 1 3/8" | 35mm |
| 5/8" | 16mm | 1 9/16" | 40mm |
| 11/16" | 18mm | 1 3/4" | 45mm |
| 3/4" | 19mm | 2" | 50mm |

Sewing Hemmer

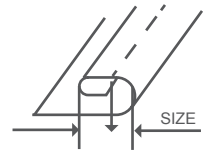

A30 / 121586 for FEED OFF ARM MACHINES 衣袖接缝器



Tape Size

| | |
|-------|--------|
| 1/4H | 3/16H |
| 1/4M | 3/16M |
| 1/4MH | 3/16MH |
| 1/4XH | 3/16XH |
| 1/4XL | |

Lap Seam Folder

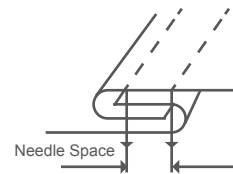

A70 / S70 for FEED OFF ARM MACHINES



Tape Size

| | |
|-------|------|
| 1/16" | 1/4" |
| 1/8" | 3/8" |
| 3/16" | 1/2" |

Shirts Tail Spring Hemmer

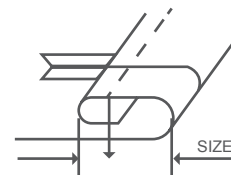

A75D / S75D for SINGLE NEEDLE LOCKSTITCH MACHINES 反下散口拉脚筒



Tape Size

| |
|------|
| 1/2" |
| 1/4" |
| 3/8" |

Single Downturn Hemmer

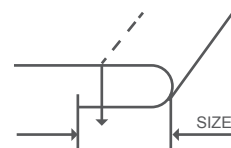

A75U / S75U for SINGLE NEEDLE LOCKSTITCH MACHINES 反上散口拉脚筒



Tape Size

- 1/2"
- 1/4"
- 3/8"

Single Upturn Hemmer

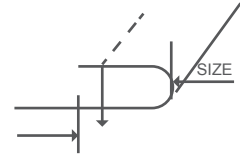

A400 / S400 for SINGLE NEEDLE LOCKSTITCH MACHINES



Tape Size

- 1/16" 1/4"
- 1/8" 3/8"
- 3/16" 1/2"

Plain Hemmer

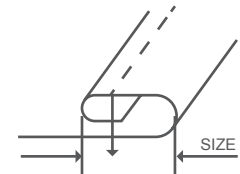

A450 / S450 for SINGLE NEEDLE LOCKSTITCH MACHINES



Tape Size

- 1/16"
- 1/8"
- 1/4"
- 3/16"

Spring Hemmer

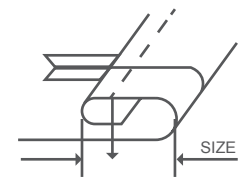

SW75D for SINGLE NEEDLE LOCKSTITCH MACHINES



Tape Size

- 1/2"
- 1/4"
- 3/8"

Single Downturn Hemmer

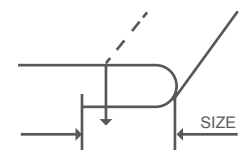



S123 / K710NA for COVERSTITCH MACHINES



Right Angle Bias Binder-A Type

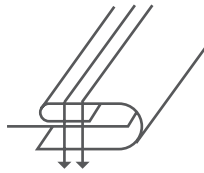

| <u>Tape Size</u> | | <u>Finished Size</u> | |
|------------------|------|----------------------|------|
| 13/16" | 20mm | 1/4" | 6mm |
| 1" | 25mm | 5/16" | 8mm |
| 1 3/16" | 30mm | 3/8" | 10mm |
| 1 1/4" | 32mm | 7/16" | 12mm |
| 1 3/8" | 35mm | 1/2" | 13mm |
| 1 1/2" | 38mm | 9/16" | 14mm |
| 1 9/16" | 40mm | 19/32" | 15mm |
| 1 9/16" | 40mm | 5/8" | 16mm |
| 1 5/8" | 42mm | 11/16" | 17mm |
| 1 3/4" | 45mm | 11/16" | 18mm |
| 1 7/8" | 48mm | 3/4" | 19mm |
| 2" | 50mm | 13/16" | 20mm |
| 2 3/16" | 55mm | 7/8" | 22mm |
| 2 3/8" | 60mm | 1" | 25mm |
| 2 9/16" | 65mm | 1 1/8" | 28mm |
| 2 3/4" | 70mm | 1 3/16" | 30mm |
| 3" | 75mm | 1 1/4" | 32mm |
| 3" | 75mm | 1 5/16" | 34mm |

Right Angle Bias Binder-B Type

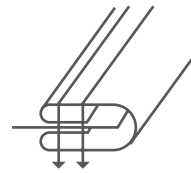

| <u>Tape Size</u> | | <u>Finished Size</u> | |
|------------------|------|----------------------|------|
| 1" | 25mm | 1/4" | 6mm |
| 1 3/16" | 30mm | 5/16" | 8mm |
| 1 3/8" | 35mm | 3/8" | 10mm |
| 1 9/16" | 40mm | 7/16" | 12mm |
| 1 9/16" | 40mm | 1/2" | 13mm |
| 1 3/4" | 45mm | 9/16" | 14mm |
| 2" | 50mm | 5/8" | 16mm |
| 2 3/16" | 55mm | 11/16" | 18mm |
| 2 3/8" | 60mm | 13/16" | 20mm |
| 2 9/16" | 65mm | 7/8" | 22mm |
| 2 3/4" | 70mm | 1" | 25mm |
| 3" | 75mm | 1 1/8" | 28mm |
| 1 3/16" | 80mm | 1 3/16" | 30mm |
| 3 3/8" | 85mm | 1 5/16" | 34mm |

S124 / K712NA for COVERSTITCH MACHINES



Right Angle Bias Binder-A Type

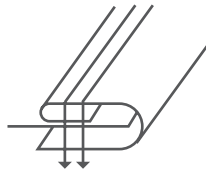

| <u>Tape Size</u> | | <u>Finished Size</u> | |
|------------------|------|----------------------|------|
| 13/16" | 20mm | 1/4" | 6mm |
| 1" | 25mm | 5/16" | 8mm |
| 1 3/16" | 30mm | 3/8" | 10mm |
| 1 1/4" | 32mm | 7/16" | 12mm |
| 1 3/8" | 35mm | 1/2" | 13mm |
| 1 1/2" | 38mm | 9/16" | 14mm |
| 1 9/16" | 40mm | 19/32" | 15mm |
| 1 9/16" | 40mm | 5/8" | 16mm |
| 1 5/8" | 42mm | 11/16" | 17mm |
| 1 3/4" | 45mm | 11/16" | 18mm |
| 1 7/8" | 48mm | 3/4" | 19mm |
| 2" | 50mm | 13/16" | 20mm |
| 2 3/16" | 55mm | 7/8" | 22mm |
| 2 3/8" | 60mm | 1" | 25mm |
| 2 9/16" | 65mm | 1 1/8" | 28mm |
| 2 3/4" | 70mm | 1 3/16" | 30mm |
| 3" | 75mm | 1 1/4" | 32mm |
| 3" | 75mm | 1 5/16" | 34mm |

Right Angle Bias Binder-B Type

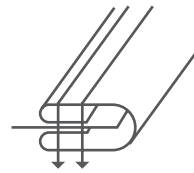

| <u>Tape Size</u> | | <u>Finished Size</u> | |
|------------------|------|----------------------|------|
| 1" | 25mm | 1/4" | 6mm |
| 1 3/16" | 30mm | 5/16" | 8mm |
| 1 3/8" | 35mm | 3/8" | 10mm |
| 1 9/16" | 40mm | 7/16" | 12mm |
| 1 9/16" | 40mm | 1/2" | 13mm |
| 1 3/4" | 45mm | 9/16" | 14mm |
| 2" | 50mm | 5/8" | 16mm |
| 2 3/16" | 55mm | 11/16" | 18mm |
| 2 3/8" | 60mm | 13/16" | 20mm |
| 2 9/16" | 65mm | 7/8" | 22mm |
| 2 3/4" | 70mm | 1" | 25mm |
| 3" | 75mm | 1 1/8" | 28mm |



SW75U for SINGLE NEEDLE LOCKSTITCH MACHINES



Single Upturn Hemmer

Tape Size

- 1/2"
- 1/4"
- 3/8"

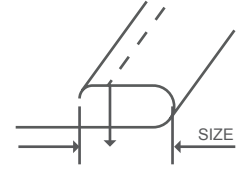

WB301 for WAIST BAND FOLDER 裤头筒



Thickness Standard:H/XH

Finished Sizes a

- a:1" IN:2 3/4"
- a:1 IN:3"
- a:3/16" IN:3 1/8"
- a:1 1/4" IN:3 1/4"
- a:1 3/8" IN:3 1/2"

Folded Size b:3/8"

- a:1 1/2" IN:3 3/4"
- a:1 5/8" IN:4"
- a:1 3/4" IN:4 1/4"
- a:1 7/8" IN:4 1/2"
- a:2" IN:4 3/4"

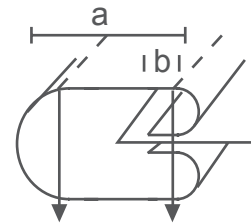

WB302 for WAIST BAND FOLDER with LINIG 落朴裤头筒



Thickness Standard:H/XH

Finished Sizes a

- a:1" IN:2 3/4"
- a:1 1/2" IN:3"
- a:1 3/16" IN:3 1/8"
- a:1 1/4" IN:3 1/4"
- a:1 3/8" IN:3 1/2"

Folded Size b:3/8"

- a:1 1/2" IN:3 3/4"
- a:1 5/8" IN:4"
- a:1 3/4" IN:4 1/4"
- a:1 7/8" IN:4 1/2"
- a:2" IN:4 3/4"

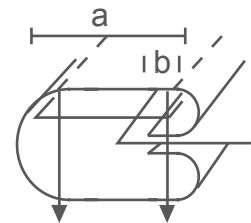

WB307 for TWO PIECES WAIST BAND FOLDER 上下布裤头筒



Thickness Standard:H/XH

Finished Sizes a

- a:1" IN:1 3/4"
- a:1 1/8" IN:1 7/8"
- a:1 3/16" IN:1 15/16"
- a:1 1/4" IN:2"
- a:1 3/8" IN:2 1/8"

Folded Size b:3/8"

- a:1 1/2" IN:2 1/4"
- a:1 5/8" IN:2 3/8"
- a:1 3/4" IN:2 1/2"
- a:1 7/8" IN:2 5/8"
- a:2" IN:2 3/4"

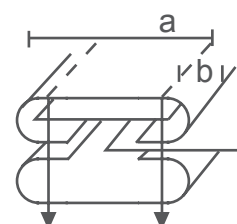

WB308 for TWO PIECES CURVE WAIST BAND FOLDER



Thickness Standard:H/XH

Finished Sizes a

a:1 1/4" IN:2 1/4"
 a:1 3/8" IN:2 3/8"
 a:1 1/2" IN:2 1/2"

Folded Size b:1/2"

a:1 5/8" IN:2 5/8"
 a:1 3/4" IN:2 3/4"

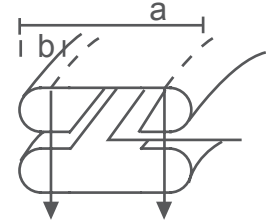

WB309 for TWO PIECES WAIST BAND FOLDER 上下布裤头筒 - 散底



Thickness Standard:H/XH

Finished Sizes a

a:1" IN:1 3/4"
 a:1 1/8" IN:1 7/8"
 a:1" IN:1"
 3/16" 15/16"
 a:1 1/4" IN:2"
 a:1 3/8" IN:2 1/8"

Folded Size b:3/8"

a:1 1/2" IN:2 1/4"
 a:1 5/8" IN:2 3/8"
 a:1 3/4" IN:2 1/2"
 a:1 7/8" IN:2 5/8"
 a:2" IN:2 3/4"

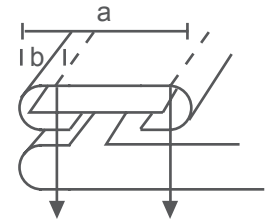

WB313 for BOTTOM WAIST BAND FOLDER 贴底包橡根裤头



Thickness Standard:H/XH

Finished Sizes a

* a:1" IN:1 3/4"
 * a:1 1/8" IN:1 7/8"
 * a:1" IN:1"
 3/16" 15/16"
 a:1 1/4" IN:2 1/4"
 a:1 3/8" IN:2 3/8"
 *b:3/8"

Folded Size b:1/2"

a:1 1/2" IN:2 1/2"
 a:1 5/8" IN:2 5/8"
 a:1 3/4" IN:2 3/4"
 a:1 7/8" IN:2 7/8"
 a:2" IN:3"

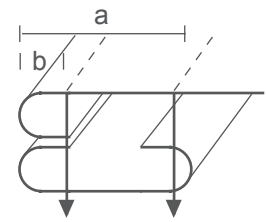

CP201 Top Center Plait Folder 恤衫明筒



Thickness Standard:S/M

Finished Sizes a

* a:7/8" IN:1 5/8"
 * a:1" IN:1 3/4"
 * a:1 1/8" IN:1 7/8"
 a:1 3/16" IN:2 3/16"
 a:1 1/4" IN:2 1/4"

Folded Size b:1/2"

a:1 3/8" IN:2 3/8"
 a:1 1/2" IN:2 1/2"
 a:1 5/8" IN:2 5/8"
 a:1 3/4" IN:2 3/4"

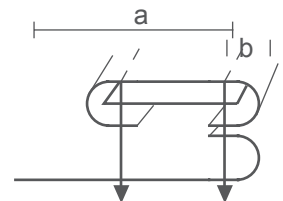

*b:3/8"



CP203 Top Center Plait Hemmer 恤衫拉筒

Thickness Standard:S/M



Finished Sizes a

- a:7/8" c:1/2~3/4"
- a:1" c:1/2~7/8"
- a:1 1/8" c:5/8~1"
- a:1 3/16" c:11/16~1 1/16"
- a:1 1/4" c:3/4~1 1/8"

Folded Size b:1/2"

- a:1 3/8" c:7/8~1 1/4"
- a:1 1/2" c:1~1 3/8"
- a:1 5/8" c:1 1/8~1 1/2"
- a:1 3/4" c:1 1/4~1 5/8"

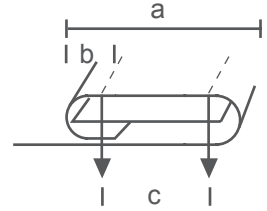

CP204 Imitation Folder 假反筒

Thickness Standard:S/M



Finished Sizes a

- a:1" b:1/4" c:5/8"
- a:1" b:5/16" c:1/2"
- a:1 1/8" b:1/4" c:3/4"
- a:1 1/8" b:5/16" c:5/8"
- a:1 3/16" b:1/4" c:13/16"
- a:1 3/16" b:5/16" c:11/16"
- a:1 1/4" b:1/4" c:7/8"

Folded Size b:1/2"

- a:1 1/4" b:5/16" c:3/4"
- a:1 3/8" b:1/4" c:1"
- a:1 3/8" b:5/16" c:7/8"
- a:1 1/2" b:1/4" c:1 1/8"
- a:1 1/2" b:5/16" c:1"
- a:1 5/8" b:1/4" c:1 1/4"
- a:1 5/8" b:5/16" c:1 1/8"

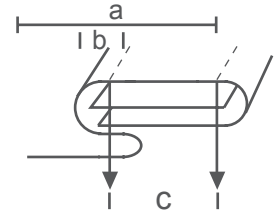

BP206 Plait Folder 拉钮子筒

Thickness Standard:S/M



Finished Sizes a

- a:7/8" b:13/16"
- a:1" b:15/16"
- a:1 1/8" b:1 1/16"
- a:1 3/16" b:1 1/8"

Folded Size b

- a:1 1/4" IN:1 3/16"
- a:1 3/8" IN:1 5/16"
- a:1 1/2" IN:1 7/16"

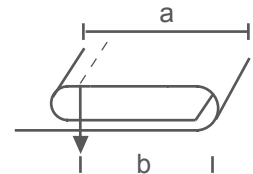

BP207 Plait Folder with Interlining 拉钮子筒有朴

Thickness Standard:S/M



Finished Sizes a

- a:3/4"
- a:7/8"
- a:1"
- a:1 1/8"

Folded Size b:3/8"

- a:1 3/16"
- a:1 1/4"
- a:1 3/8"
- a:1 1/2"

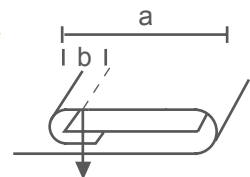

EB531 Edge Binder 捆边蝴蝶 (散口)



Thickness Standard:M

Finished Sizes a

| | |
|---------|-----------|
| a:3/16" | IN:3/8" |
| a:1/4" | IN:1/2" |
| a:5/16" | IN:5/8" |
| a:3/8" | IN:3/4" |
| a:1/2" | IN:1" |
| a:9/16" | IN:1-1/8" |
| a:7/16" | IN:7/8" |
| a:3/4" | IN:1-1/2" |

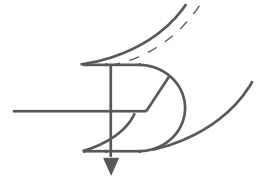

BK213 Single Needle Shirt Yoke Attachment 单针担捍蝴蝶



Thickness Standard:M

Finished Sizes b

b:3/8"

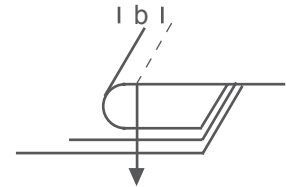

ST211 Single Needle Shoulder Top Stitch Attachment 单针纳膊蝴蝶



Thickness Standard:S/M

Finished Sizes b

b:3/8"

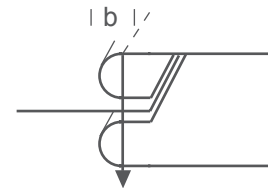

RS219 Sleeve Placket Binder 侧袖筒



Thickness Standard:M/MH

Finished Sizes a

| | | |
|---------|--------|-----------|
| a:1/4" | b:1/4" | IN:1" |
| a:5/16" | b:1/4" | IN:1 1/8" |
| a:3/8" | b:1/4" | IN:1 1/4" |
| a:1/2" | b:1/4" | IN:1 1/2" |

Folded Size b:3/8"

| | | |
|--------|--------|-----------|
| a:5/8" | b:3/8" | IN:2" |
| a:3/4" | b:3/8" | IN:2 1/4" |
| a:7/8" | b:3/8" | IN:2 1/2" |
| a:1" | b:3/8" | IN:2 3/4" |





CB501 Single up turn folder 散口蝴蝶



Thickness Standard:M

Finished Sizes

| | | |
|-------|------|--------|
| 3/16" | 3/8" | 1" |
| 1/4" | 1/2" | 1 1/4" |
| 5/16" | 3/4" | 1 1/2" |

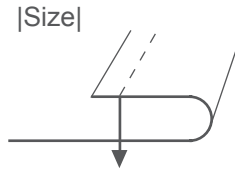

LO516 Belt Loop Folder 耳仔筒



Thickness Standard:M

Finished Sizes: a

| | |
|---------|-----------|
| a:3/16" | IN:3/4" |
| a:1/4" | IN:1" |
| a:5/16" | IN:1 1/4" |
| a:3/8" | IN:1 3/8" |

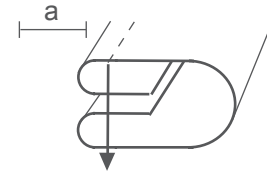

CH502 Swing Hemmer Foot 拉圆脚蝴蝶靴



Thickness Standard:S/M

Finished Sizes

| |
|-------|
| 1/8" |
| 3/16" |
| 1/4" |

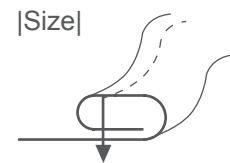

CP527 Suspend Waist Band Attachment 裤腰吊筒蝴蝶



| a | c | Bias Tape Size |
|--------|------|----------------|
| 3/8" | 1/4" | 7/8" |
| 1/2" | 3/8" | 1 1/8" |
| 5/8" | 1/2" | 1 3/8" |
| 3/4" | 5/8" | 1 1/2" |
| 7/8" | 3/4" | 1 5/8" |
| 1" | 7/8" | 1 3/4" |
| 1 1/8" | 1" | 1 7/8" |

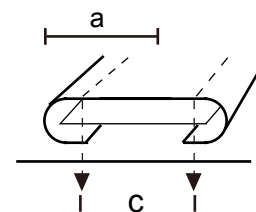

LO515 Loop Folder 耳仔筒靴



Thickness Standard:M

Finished Sizes: a

- a:1/8" IN:1/2"
- a:3/16" IN:3/4"
- a:1/4" IN:1"

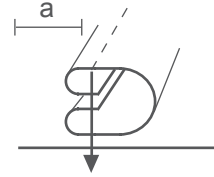

LO535 Spaghetti Attachment 暗线耳仔筒

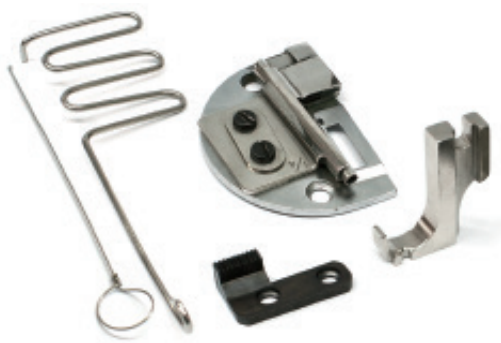

Thickness Standard:S/M

Finished Sizes: a

- a:1/8" IN:5/8" a:5/16" IN:1 1/4"
- a:3/16" IN:7/8" a:3/8" IN:1 3/8"
- a:1/4" IN:1" a:1/2" IN:1 3/4"

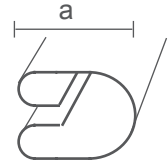

CH503 Short Tail Swing Hemmer 拉圓腳蝴蝶



Thickness Standard:S/M

Finished Sizes: a

- 1/8"
- 3/16"
- 1/4"
- 5/16"

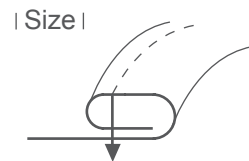

BL339 Belt Loop Folder 耳仔筒



c Tape Size

Finished Size

- | | |
|------|------|
| 15mm | 6mm |
| 18mm | 7mm |
| 20mm | 8mm |
| 22mm | 9mm |
| 24mm | 10mm |
| 26mm | 11mm |
| 30mm | 13mm |
| 34mm | 15mm |
| 38mm | 18mm |
| 45mm | 20mm |

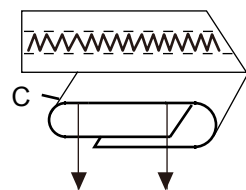



BL340 Belt Loop Folder 耳仔筒



Thickness Standard:H/XH

Finished Sizes: a

| | |
|--------|-----------|
| a:3/8" | IN:7/8" |
| a:1/2" | IN:1 1/8" |
| a:5/8" | IN:1 3/8" |

Needle Space c:1/4"

| | |
|--------|-----------|
| a:3/4" | IN:1 5/8" |
| a:7/8" | IN:1 7/8" |
| a:1" | IN:2 1/8" |

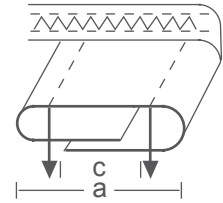

BL342 Belt Loop Folder 耳仔筒



Thickness Standard:H/XH

Finished Sizes: a

H:

| | |
|--------|-----------|
| a:3/8" | IN:7/8" |
| a:1/2" | IN:1 1/8" |
| a:5/8" | IN:1 3/8" |
| a:3/4" | IN:1 5/8" |

Needle Space c:1/4"

XH:

| | |
|----------|------------|
| a:7/8" | IN:1 7/8" |
| a:1" | IN:2 1/8" |
| a:3/8" | IN:7/8" |
| a:1 1/2" | IN:1" 1/8" |

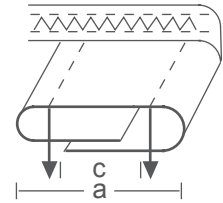

BS333/LS333 Lap seam Folder 上袖蝴蝶



Thickness Standard:H/XH

Finished Sizes a

| |
|---------|
| a:5/16" |
| a:3/8" |

Needle Space c

| |
|---------|
| c:3/16" |
| c:1/4" |

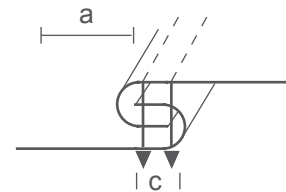

BS334/LS334 Spring type Seam Lap Folder 上袖蝴蝶



Thickness Standard:H/XH

Finished Sizes a

| |
|---------|
| a:5/16" |
| a:3/8" |

Needle Space c

| |
|---------|
| c:3/16" |
| c:1/4" |

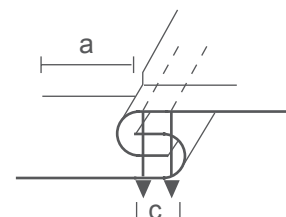

BS337/FA337 Spring type side seam Folder 弹弓阻日字埋夹蝴蝶



Thickness Standard:M/MH/H/XH

Finished Sizes a:7/16"

Needle Space c:9/32"

M:5/16"
MH:3/8"
H:5/16"
XH:3/8"

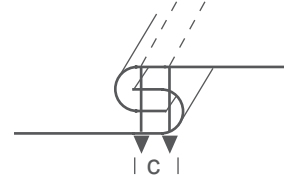

BL340 Belt Loop Folder 耳仔筒



Thickness Standard:H/XH

Finished Sizes a

Needle Space c:1/4"

a:3/8"
a:1/2"
a:5/8"

IN:7/8"
IN:1 1/8"
IN:1 3/8"

a:3/4"
a:7/8"
a:1"

IN:1 5/8"
IN:1 7/8"
IN:2 1/8"

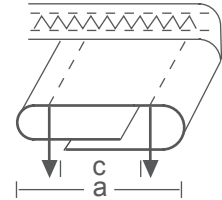



針板 NEEDLE PLATE



NEEDLE PLATE for OVERLOCK & INTERLOCK SEWING MACHINES - **BROTHER** 兄弟 針板

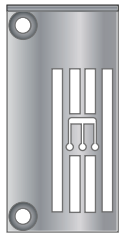

S08723-001
B271-011
B272-011 356

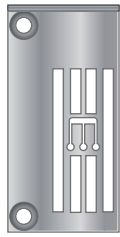

S08724-001
B271-011
B272-011 364

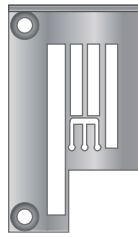

S08731-001
B271-021
B272-021 356

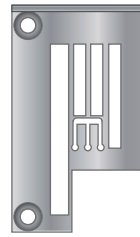

S08732-001
B271-021
B272-021 364

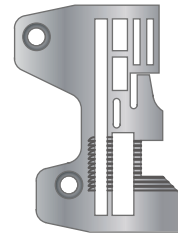

146781-001

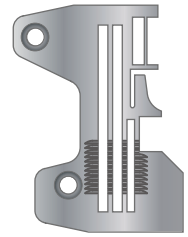

S19145-001

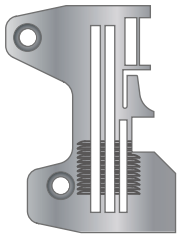

S19146-001
EF4-N11 -01-5 5mm

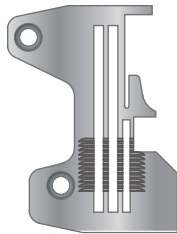

S19154-001
EF4-N11 -01-5(B)
5mm

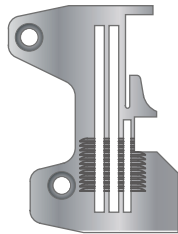

S19155-001
EF4-N11 -01-4(B)
4mm

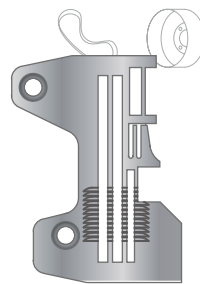

S19162-001
EF4-N21-22-5 2.2x5

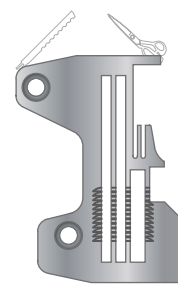

S19166-001
EF4-N21-27-5 2.2x5

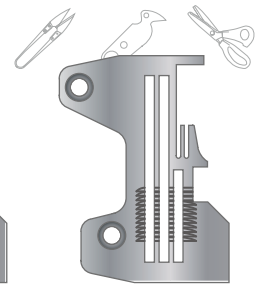

S19169-001
EF4-N21-45-5 2.2x5

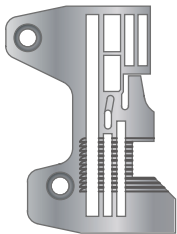

S19185-001
EF4-N31-92-5 5x5

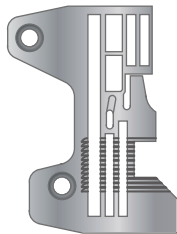

S19186-001
EF4-N31-92-6 5x6

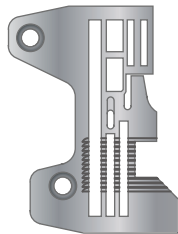

S20232-001
EF4-N31-65-5 5x5

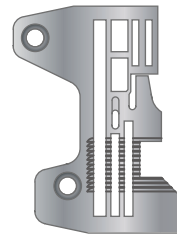

S20234-001
EF4-N31-63-3 3x3

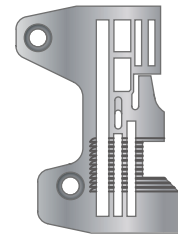

S20236-001
EF4-N31-63-5 3x5

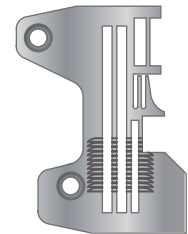

S25190-001
EF4-N21-22-4 2.2x4



NEEDLE PLATE for OVERLOCK & INTERLOCK SEWING MACHINES - **JUKI**

重机 針板

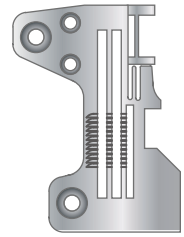
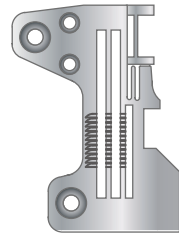
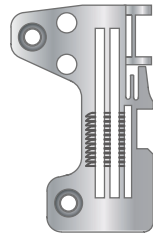
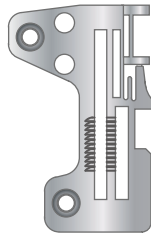
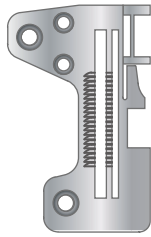
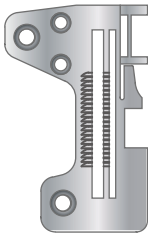

R4200-HOD-D00
MO-2504-OD4-210
3.2

R4200-JOE-D00
MO-3904-OE4 4mm

R4205-HOD-EAO
MO-2514-BD4-200
2x3.2

R4305-HOD-E00
MO-2514-BO6-340
2x3.2

R4305-JOE-E00
MO-3914-BE6 2x4

R4305-J6E-E00

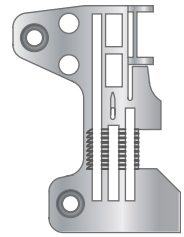
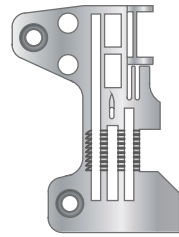
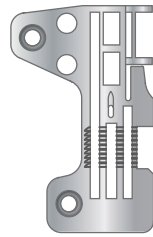
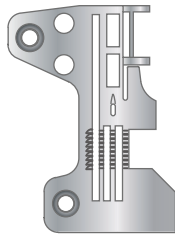
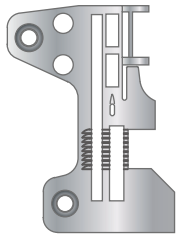
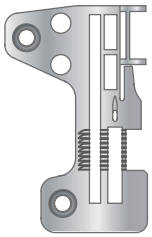

R4508-HOD-D00
MO-2516-DD4-300
3.2x3.2

R4508-JOE-D00
MO-3916-DD4
3.2x4

R4608-JOE-D00
MO-3916-DE6 3.2x4

R4612-HOF-G00
MO-2516-FF6-500
4.8x4.8

R4612-JOD-E01
MO-3943-FBD6
4.8x3.2

R4612-JOF-D00
MO-3916-FF6
4.8x4.8

NEEDLE PLATE for OVERLOCK & INTERLOCK SEWING MACHINES - **KANSAI-SP** 关西 針板

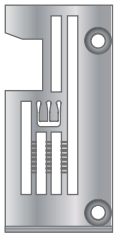

14-7900-0
WX8003EMK 356

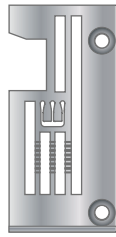

14-7910-0
WX8003EMK 364

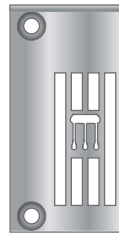

14-8190-0
WX8703D 356

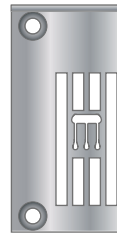

14-8200-0
WX8703D 364

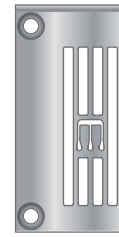

14-8460-0
WX8803C 356

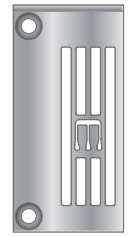

14-8470-0
WX8803C 364

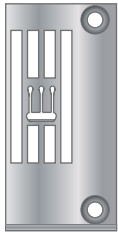

14-8540-0
W8003D W8103D
356

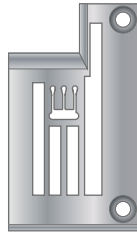

14-8560-0
W8003F 356

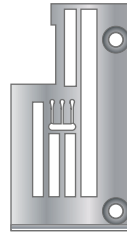

14-8580-0
W8003EMK 356

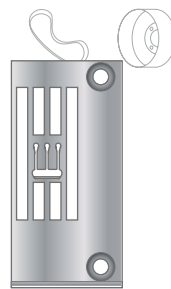

14-8640-0
W8003D W8103D
364

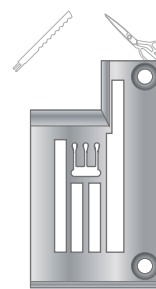

14-8660-0
W8003F 364

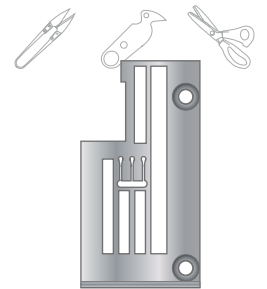

14-8680-0
W8003EMK 364

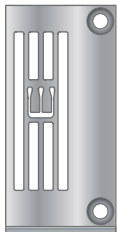

14-8900-0
WX8803D 356

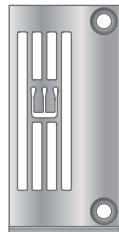

14-8910-0
WX8803D 364



NEEDLE PLATE for OVERLOCK & INTERLOCK SEWING MACHINES - PEGASUS 飞马 針板

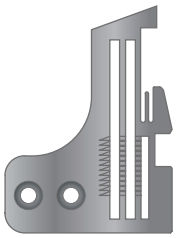

202554E
M852-13 2x4

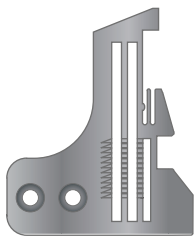

202554E1
M852-13 2x4

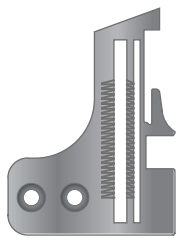

202618A
R53-01/M752-180
4mm

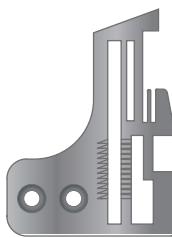

202675
R53-05 2x4

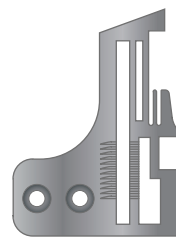

202702
R53-05 2x3

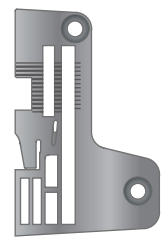

204360A
L32-70 5x5

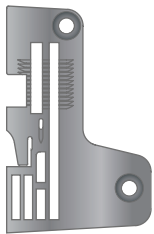

204367
L32-36.38 3X4

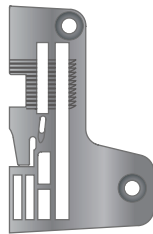

204528
L32--86 5x5

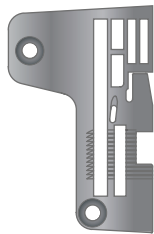

204529
L32--86 5x6

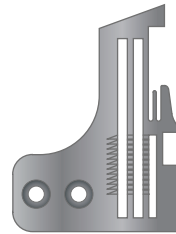

205255
L52/ M752-13 2x3

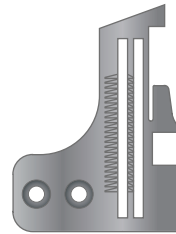

205773
L52/ M752-01 4mm

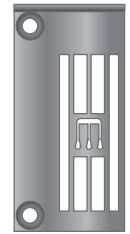

257018B56
W562-01CB 356

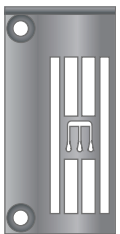

257018B64
W562-01CB 364

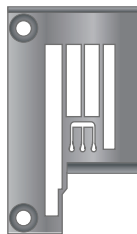

257033B56
W562-02BB 356

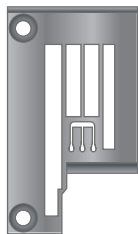

257033B64
W562-02BB 364

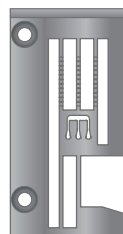

257053B56
W562-05BB 356

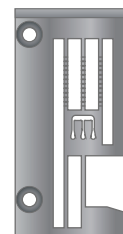

257053B64
W562-05BB 364

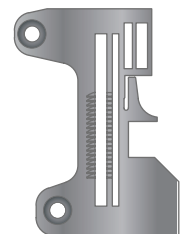

277500P30
EX5204-01/233K
3mm

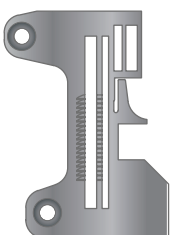

277500P40
EX5204-01/233K
4mm

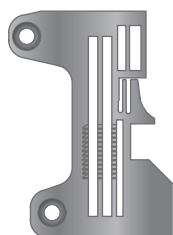

277505R30
EX5212-02/333K
2x3

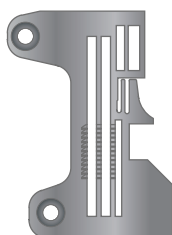

277505R40
EX5212-02/333K
2x4

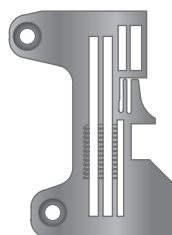

277505R50
EX5212-02/333K
2x5

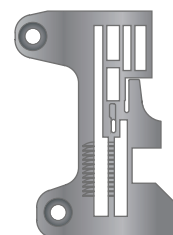

277513R30
EX3216-02/223K
3x3

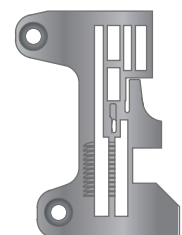

277513R40
EX3216-02/223K
3x4

NEEDLE PLATE for OVERLOCK & INTERLOCK SEWING MACHINES - PEGASUS

飞马 针板

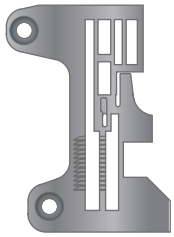

277513R50
EX3216-02/223K
3x5

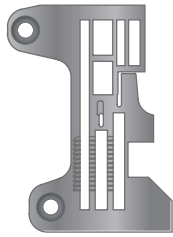

277516R40
EX3216-03/223K
5x6

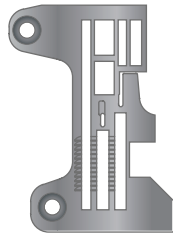

277516R50
EX3216-03/223K
5x5

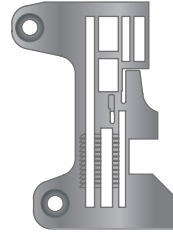

277517R40
EX3216-03/223K
3x4

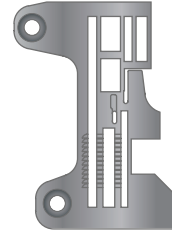

277517R50
EX3216-03/223K
3x5

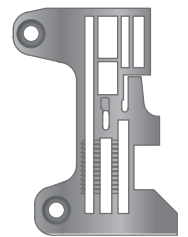

277524T50
EX3216-04/435K
5x5

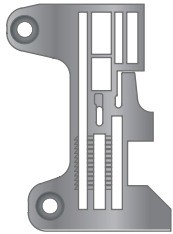

277524T60
EX3216-04/435K
5x6





NEEDLE PLATE for OVERLOCK & INTERLOCK SEWING MACHINES - **SIRUBA** 银箭 针板

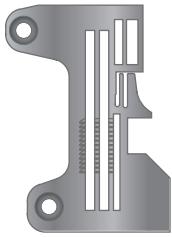

E229

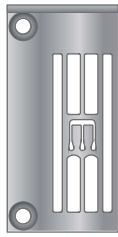

E1826
F007E-W122/UTG
356

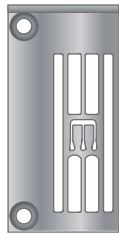

E1827

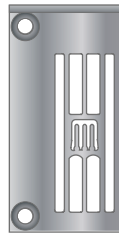

E1828

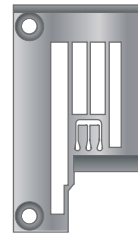

E3326
F007E-W222/FQ
356

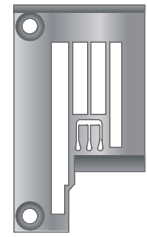

E3327
F007E-W222/FQ
364



E3524P
C007E-W122/CH/
UTP 240



E3826P
C007E-W122/CH/
UTR 356



E3827P
C007E-W122/CH/
UTR 364

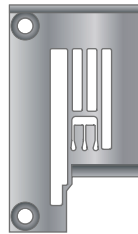

E4426P
C007E-W222/CQ
356

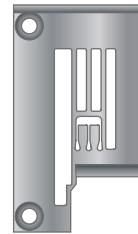

E4427P
C007E-W222/CQ
364

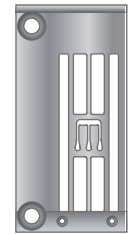

E4826
F007E- W333/FDC
356

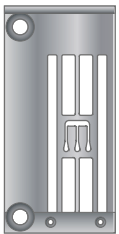

E4827
F007E- W333/FDC
364

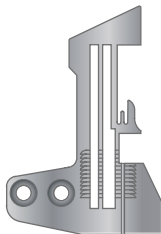

E591B
747F-514M2-23BK-
VT 2x3

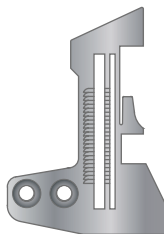

E784
737D-503F1-04
4 mm

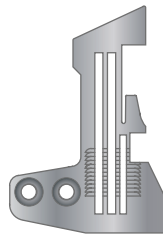

E797
737D-504M3-05
5mm

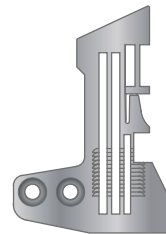

E800
737D-504M2-04
4mm

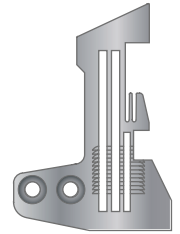

E805
747D-514M4-24 2x4

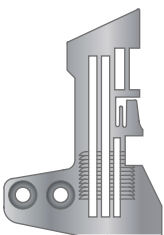

E809
747D-512M1-24 2x4
747D-512M2-25 2x5

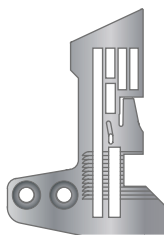
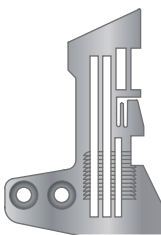

E839
757-516L1-35 3x5

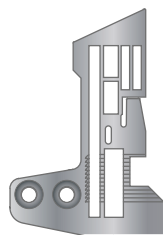

E854
757-516M1-33 3x3

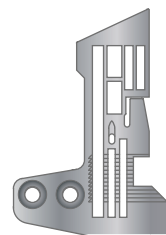

E868
757-516X2-56 5x6t

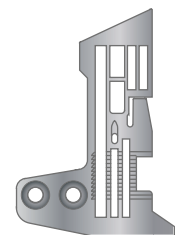

E870
757F-516X2-56 5x6

NEEDLE PLATE for OVERLOCK & INTERLOCK SEWING MACHINES - **SIRUBA** 银箭 针板

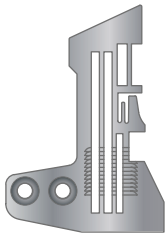

E919

747F-514M2-24 2x4 747F-514M2-25 2x5

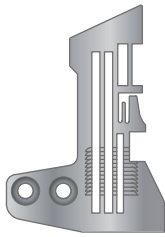

E920

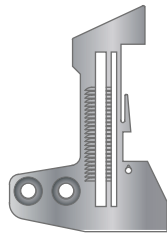

E934

737D-504M1-15
1.5mm

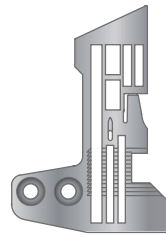

E982

757-516M-35 3x5

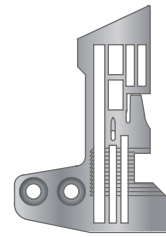

E986

757-516M2-55 5x5

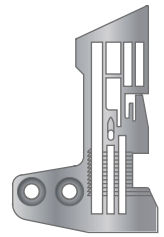

E988

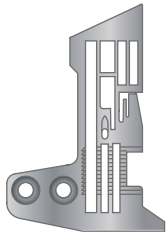

E989





NEEDLE PLATE for OVERLOCK & INTERLOCK SEWING MACHINES - **YAMATO** 大和 針板

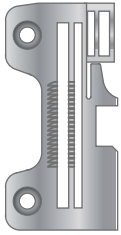

2108000
AZ8000H-04
4mm

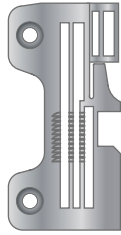

2108003
AZ8003H-04
4mm

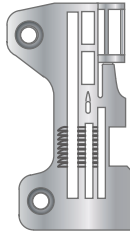

2108052
AZ8502H-C5 5x5

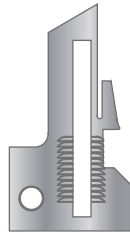

32667
DCZ-200-D2

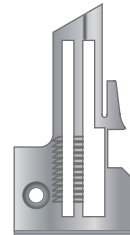

32672
DCZ-203-D2 3.5

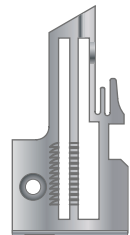

33353
DCZ-220-D1

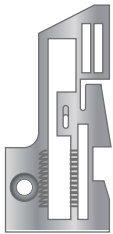

33545
DCZ-361C-D3

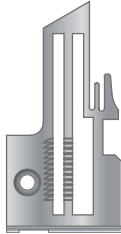

34598
DCZ-520-D1

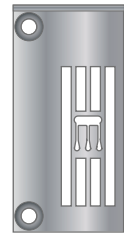

94801
VF-2500 356

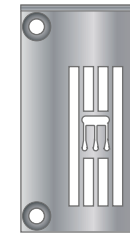

94802
VF-2500 364



94902
VC-2703 364

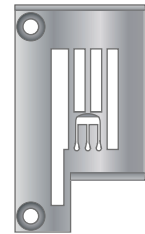

95085
VF-2503 356



3108134

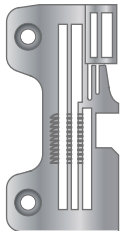

2108004

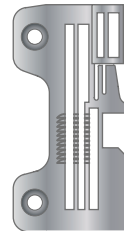

2108005

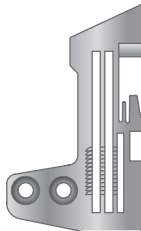

21787
Z5020-Y6

N/P & F/G for SINGLE NEEDLE LOCKSTITCH SEWING MACHINES

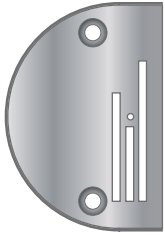

B14
Needle Plate

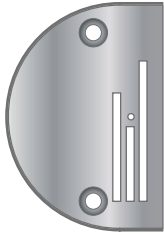

B16
Needle Plate

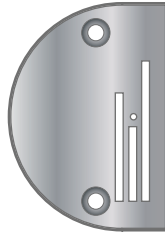

B18
Needle Plate

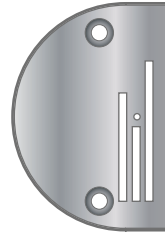

B20
Needle Plate

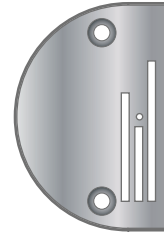

B22
Needle Plate

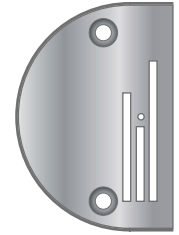

B24
Needle Plate

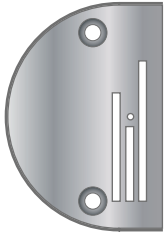

B26
Needle Plate

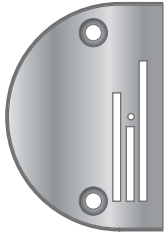

B28
Needle Plate

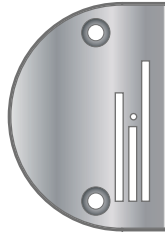

B30
Needle Plate

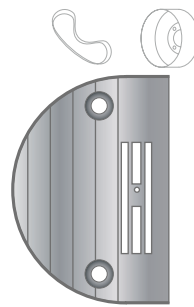

E14
Needle Plate

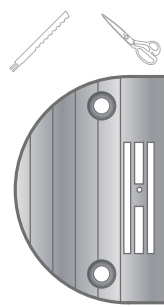

E16
Needle Plate

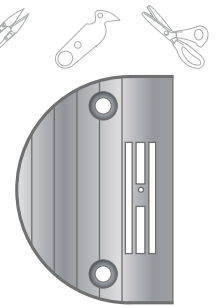

E18
Needle Plate

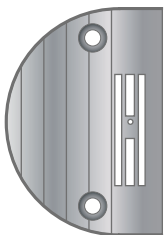

E20
Needle Plate

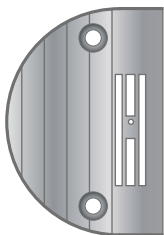

E22
Needle Plate

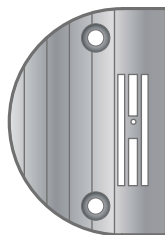

E24
Needle Plate

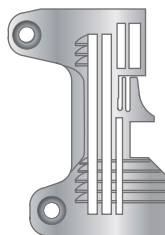

E229
Needle Plate

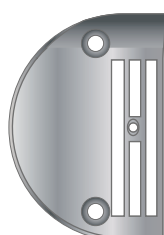

H26
Needle Plate

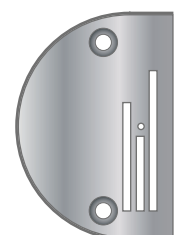

12482
Needle Plate



NEEDLE PLATE for SINGLE NEEDLE LOCKSTITCH SEWING MACHINES

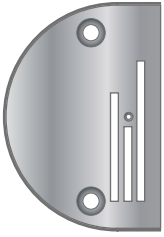

56065
Needle Plate

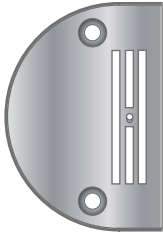

147150LGW
Needle Plate

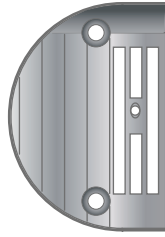

143169W
Needle Plate

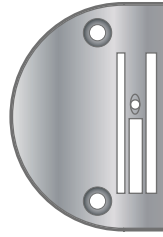

B1109-555-HOB
Needle Plate

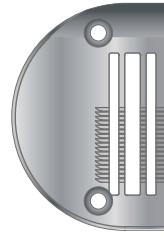

B1109-415-H00
Needle Plate

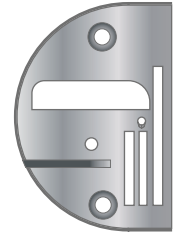

A10-NP NO.1~4
Needle Plate

送布齿
FEED DOG

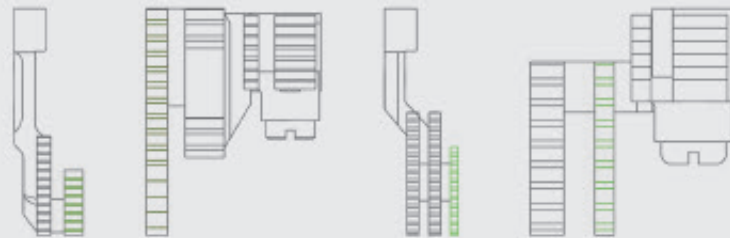



FEED DOG for OVERLOCK & INTERLOCK SEWING MACHINES - BROTHER 兄弟 送布齿



S08882-001
B271-011.B272-011



S08883-001
B271-021.B272-021



S19199-001
EF4-N11 -01-4



S19202-001
EF4-N21-27-5



S19212-001
EF4-N11 -01-4(B)



S19217-001
EF4-N21-22-4



S19219-001
EF4-N21-45-5



S19228-101
EF4-N31-92-5



S19236-001
EF4-N11 -01-4



S19237-001
EF4-N21-27-5



S19240-001
EF4-N21-22-4



S19244-001
EF4-N21-45-5



S19247-001
EF4-N31-92-5



S20239-101
EF4-N31-65-5



S20241-101
EF4-N31-63-3



S20245-001
EF4-N31-63-3



146572-001
B551-063



146573-001
B551-065



146574-001
B551-087



146748-001
B511-001



146749-001
B531-022



146567-001+
146577-001
B551-063



146568-001+
146577-001
B551-065



146569-001+
146577-001
B551-087

FEED DOG for OVERLOCK & INTERLOCK SEWING MACHINES - **BROTHER** 兄弟 送布齿



146744-001+
146577-001
B511-001



146744-001+
146577-001
B531-022



2109006+
2109067
AZ8003H-03



2109006+
2109067
AZ8020H-Y5





FEED DOG for OVERLOCK & INTERLOCK SEWING MACHINES - **JUKI** 重机 送布齿



115-97101+
118-87106
MO-2514-BD4-200



118-82107+
118-87106
MO-2504-OD4-210



118-82404+
118-87106
MO-2514-BO6-340
MO-2414N



118-82800+
118-87403
MO-2516-DD4-300
MO-3916



118-83006+
118-87304
MO-2516-FF6-500



118-85209
MO-2516-DD4-300



118-85407
MO-2516-FF6-500



118-86504
MO-2514-BO6-340
MO-2414N



119-49807+
118-87106
MO-3914-BE6



119-49906
MO-3914-BE6



121-72805
MO-3916-DD4



121-73209
MO-3916-DE6



121-73308
MO-3916-FF6



B1657-804-OOT
MO-2504-OD4-210



B1657-814-BOE
MO-2514-BD4-200
MO-6714



B1657-804-OOT
MO-2504-OA4-150



118-86504
MO-2514-BO6-340
MO-2414N



118-85407
MO-2516-DF6-500



118-86009
MO-2543-FBD6-300



124-78301
MO-3305-OE4-40H/
Z192



B1657-814-BOE
MO-3914-AD4-307



118-82107+
118-87007
MO-2504-OA4-150



118-82404+
118-87106
MO-2514-BO6-340
MO-2414n



118-84004+
118-87403
MO-2543 MO-3916
MO-3943 MO-6716
MO-6743

FEED DOG for OVERLOCK & INTERLOCK SEWING MACHINES - **JUKI** 重机 送布齿



118-84004+

124-76305+

115-97101+

118-87403

124-80307

118-87106

MO-2543-FBD6-300 MO-3305-OE4-40H/Z192 MO-3914-AD4-307





FEED DOG for OVERLOCK & INTERLOCK SEWING MACHINES - **KANSAI-SP** 关西 送布齿



15-7230-0
W8003D W8103D



15-7270-0
W8003F



15-7530-0
W8003D W8103D



15-7560-0
W8003F



15-8070-0
WX8803D



15-808
WX8703D



15-8110-0
WX8003F



15-8120-0
WX8003F



15-8230-0
WX8803C



15-3610-0
DPW-1302S



15-7600-0
B2000C



15-7040-0
B2000



15-805-0
WX8802D



15-3010-0
DPW-1302S



15-8060-0
WX8802D



15-808
WX8803D



15-8440-0
WX8803C

FEED DOG for OVERLOCK & INTERLOCK SEWING MACHINES - PEGASUS 飞马 送布齿



201094B
R53-05



202854A
R53-05



204676-BF



204730A16F
R53-01/M752-180



204730-BF
L52/ M752-01



208063
L32-70



208064
L32--86



208066
L32-36,38



208078-BF



208090A16F
R53-01/M752-180



208090-BF
L52/ M752-01



208215
L32-70



208217
L32--86



208219
L32-36,38



257207-16F
W562-01CB



257216-16F
W562-02BB



257222-16F
W562-05BB



257259-16F
W562-01CB



257262-16F
W562-02BB



257268-16F
W562-05BB



277300-16
EX5204-01/233K



277302-16
EX5204-01/233K



277303-16F
EX5212-02/333K



277305-16
EX5212-02/333K



FEED DOG for OVERLOCK & INTERLOCK SEWING MACHINES - PEGASUS 飞马 送布齿



277323-16
EX3216-02/223K



277325-16
EX3216-02/223K



277327-16
EX3216-03/223K



277329-16
EX3216-03/223K



277330-16
EX3216-03/223K



277337-25
EX3216-04/435K



277339-25
EX3216-04/435K



S08885-001
B271-011,B272-011



S08886-001
B271-021,B272-021



257258-16F
W561-01CB



257261-16F
W561-01CB



257267-16F
W561-03 DB



257289-16F
W664-01CB



257290-16F
W664-01CB



259215-16F
W664-03FB



259203-16F
W664-35BB



204730-BF
L52/ M752-16S1



208219
L32-359 /732-354



208217
L32--34



277305-16
EX5204-02/223K



277329-16
EX3244-03/333K



257206-16F
W561-01CB/W562-01CB



257215-16F
W561-01CB/W562-01CB



257207-16F
W561-03 DB

FEED DOG for OVERLOCK & INTERLOCK SEWING MACHINES - **PEGASUS** 飞马 送布齿



257221-16F
W561-05BB/W562-05BB



257242-16F
W664-01CB



257243-16F
W664-01CB



259103-16F
W664-03FB



259101-16F
W664-35BB



208911
L52/ M752-16S1



208066
L32-359 /732-354



208064
L32--34



277303-16
EX5204-02/223K



277327-16
EX3244-03/333K



FEED DOG for OVERLOCK & INTERLOCK SEWING MACHINES - **SIRUBA** 银箭 送布齿



D1207
F007E-W122



D1216
F007E-W222/FQ



D290
737D-504M1-15



D3216
C007E-W222/CQ



D3217
C007E-W222/CQ



D390
747F-514M2-23BK-
VT



D4206
C007E-W122/CH



D4207
C007E-W122/CH



D569
737D-503F1-04



D574
737D-504M3-05



D575
747D-512M1-24



D579
757-516L1-35



D581
757-516M1-33



D582
757-516X2-56



H1259
F007E-W122



H1262
F007E-W222/FQ



H1359
F007E- W333/FDC



H3362
C007E-W222/CQ



H3363
C007E-W222/CQ



H4258
C007E-W122/CH



H4259
C007E-W122/CH



H442
737D-503F1-04



H445
747D-512M1-24



H492
757-516L1-35

FEED DOG for OVERLOCK & INTERLOCK SEWING MACHINES - SIRUBA 银箭 送布齿



H494
757-516M1-33



H497
757-516M-35



H500
757-516M2-55



H501
757-516X2-56



H974
747F-514M2-23BK-
VT



H1258
F007E-W122



H3159
F007E-W122



D1206
F007E-W122
W122/UTG(UTJ)



D1207
C007E-U322/CE



FEED DOG for OVERLOCK & INTERLOCK SEWING MACHINES - **YAMATO** 大和 送布齿



2109000
AZ8000H-04



2109001+
2109067
AZ8000H-04



2109005
AZ8003H-04



2109006+
2109067
AZ8003H-04



2109055
AZ8502H-C5



2109056+
2109052
AZ8502H-C5



3109000
VC-2700



3109001
VC-2700



3109002
VC-2700



3109003
VC-2700



3109020
VC-2703



3109021
VC-2703



3209000
VF-2500



3209001
VF-2500



3209002
VF-2500



3209003
VF-2500



3209008
VF-2503



3209009
VF-2503



2109007
AZ8003H-03



2109005
AZ8020H-Y5



2109009
AZ8020H-Y6



3159034+
3159019
VE-2713-156S



3159034+
3159012
VE-2713-156L-2-TIN



3209001
VF-2300-156M

FEED DOG for OVERLOCK & INTERLOCK SEWING MACHINES - **YAMATO** 大和 送布齿



3209003
VF-2300-164M



3209001
VF-2400-132M



68096
FD-62G-01MR



3159037
VE-2713-156S



3209000
VF-2300-156M



3209002
VF-2300-164M



3209000
VF-2400-132M



68095
FD-62G-01MR





FEED DOG for SINGLE NEEDLE LOCKSTITCH SEWING MACHINES



12481-22
Feed Dog



12481-19
Feed Dog



12481-17
Feed Dog



12481-15
Feed Dog



12481-13
Feed Dog



12481-11
Feed Dog



12481-9
Feed Dog



272153
Feed Dog



149057
Feed Dog



150793
Feed Dog



99601
Feed Dog



149165
Feed Dog



B1613-555-HOO
Feed Dog



B1609-415-HOB
Feed Dog



B1613-522-NOO
Feed Dog



B1613-522-WOO
Feed Dog



A70 FEED DOG
Feed Dog



2002 FOR A10
Feed Dog

FEED DOG for OVERLOCK & INTERLOCK SEWING MACHINES - **SHING LING** 星菱 送布齿



FE40+FE16
FW-777-356



FE41
FW-777-356





压脚
FEET

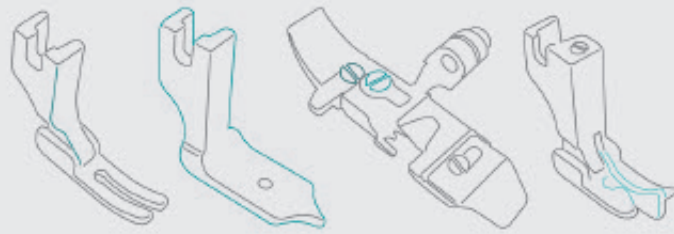

HEMMER FOOT for SINGLE NEEDLE LOCKSTITCH MACHINES

Thin material



| | |
|----------|--------------|
| NO.1 | 1/16"(1.6mm) |
| NO.1 1/2 | 5/64"(2.0mm) |
| NO.2 | 3/32"(2.4mm) |
| NO.2 1/2 | 1/8"(3.2mm) |
| NO.3 | 5/32"(4.0mm) |
| NO.4 | 3/16"(4.8mm) |
| NO.5 | 7/32"(5.6mm) |
| NO.6 | 1/4"(6.4mm) |
| NO.7 1/2 | 5/16"(8.0mm) |

Thick material



| | |
|--------|---------------|
| NO.02 | 1/8"(3.2mm) |
| NO.04 | 3/16"(4.8mm) |
| NO.06 | 1/4"(6.4mm) |
| NO.07 | 5/16"(8.0mm) |
| NO.09 | 3/8"(9.5mm) |
| NO.095 | 7/16"(11.1mm) |

PRESSER FOOT for OVERLOCK & INTERLOCK SEWING MACHINES



P253E-4(WITH HEAD)
for SIRUBA
[747D-512M1-24](#)



P502-A
for SIRUBA
[757-516M2-55](#)



S19280-001
for BROTHER
[EF4-N21-22-4](#)



S19313-201
for BROTHER
[EF4-N31-63-3](#)



S19317-001
for BROTHER
[EF4-N31-65-5](#)



S19334-001
for BROTHER
[EF4-N31-92-5](#)



208504
for PEGASUS
[L32 / M732-38,39](#)



201230C
for PEGASUS
[+210374+274018-92B](#)



201230C
for PEGASUS
[+210371+274018-92B](#)



201230C
for PEGASUS
[+210503+274018-92B](#)



277118
for PEGASUS
[EX3216-02/223K](#)



277119
for PEGASUS
[EX3216-03/223K](#)



PRESSER FOOT for OVERLOCK & INTERLOCK SEWING MACHINES



277122
for PEGASUS
EX3216-04/435K



257321A56
for PEGASUS
W561-02BB



257331A56
for PEGASUS
W561-05BB

HIRRING FEET 衿折押脚



P952
S952



P950
S950



P5
P5R
2.0mm



P5W
2.8mm

COMPENSATING FEET 高低活动押脚

CR SERIES



| | | | |
|----------------|---------------|-----------|---------------|
| CR 1/32E(21R) | 1/32" (0.8mm) | CR 1/32 | 1/32" (0.8mm) |
| CR 1/16E(211) | 1/16" (1.6mm) | CR 1/16 | 1/16" (1.6mm) |
| CR 1/8E(212) | 1/8" (3.2mm) | CR 1/32NS | 1/32" (0.8mm) |
| CR 3/16E(213) | 3/16" (4.8mm) | CR 1/16NS | 1/16" (1.6mm) |
| CR 1/4E(214) | 1/4" (6.4mm) | CR 1/32NK | 1/32" (0.8mm) |
| CR 5/16E(215R) | 5/16" (8.0mm) | CR 1/16NK | 1/16" (1.6mm) |
| CR 3/8E(216R) | 3/8" (9.5mm) | | |
| CR 1/2E(218R) | 1/2" (12.7mm) | | |

CL SERIES



| | | | |
|----------------|---------------|-----------|---------------|
| CL 1/32E(22L) | 1/32" (0.8mm) | CL 1/32 | 1/32" (0.8mm) |
| CL 1/16E(221) | 1/16" (1.6mm) | CL 1/16 | 1/16" (1.6mm) |
| CR 1/32N(210) | 1/32" (0.8mm) | CL 1/32NS | 1/32" (0.8mm) |
| CR 1/16N(211N) | 1/16" (1.6mm) | CL 1/16NS | 1/16" (1.6mm) |
| CL 1/32N(220) | 1/32" (0.8mm) | | |
| CL 1/16N(221N) | 1/16" (1.6mm) | | |

NR/NL SERIES



NR-31S 1/32" (0.8mm)
NL-31S 1/16" (1.6mm)

211 SERIES



211-13 1/16" x 3/16"
211-14 1/16" x 1/4"
211-15 1/16" x 5/16"
211-16 1/16" x 3/8"
211-18 1/16" x 1/2"

HINGED RAISING FEET 高架活动押脚

P81 L/R(12463HL/R) SERIES



| | | |
|---------------------|----------------------|---------------|
| P810(12463HR 1/32) | P810L(12463HL 1/32) | 1/32" (0.8mm) |
| P811(12463HR 1/16) | P811L(12463HL 1/16) | 1/16" (1.6mm) |
| P8115(12463HR 3/32) | P8115L(12463HL 3/32) | 3/32" (2.4mm) |
| P812(12463HR 1/8) | P812L(12463HL 1/8) | 1/8" (3.2mm) |
| P8125(12463HR 5/32) | P8125L(12463HL 5/32) | 5/32" (4.0mm) |
| P813(12463HR 3/16) | P813L(12463HL 3/16) | 3/16" (4.8mm) |
| P814(12463HR 1/4) | P814L(12463HL 1/4) | 1/4" (6.4mm) |
| P815(12463HR 5/16) | P815L(12463HL 5/16) | 5/16" (8.0mm) |
| P816(12463HR 3/8) | P816L(12463HL 3/8) | 3/8" (9.5mm) |
| P818(12463HR 1/2) | P818L(12463HL 1/2) | 1/2" (12.7mm) |

PIPPING FEET 带沟押脚

P69 L/D(36069L/DG) SERIES



| | |
|-------------------------|---------------|
| P69L 1/8(36069L 1/8) | 1/8" (3.2mm) |
| P69L 1/4(36069L 1/4) | 1/4" (6.4mm) |
| P69L 3/8(36069L 3/8) | 3/8" (9.5mm) |
| P69L 1/2(36069L 1/2) | 1/2" (12.7mm) |
| P69D 1/8(36069DG 1/8) | 1/8" (3.2mm) |
| P69D 3/16(36069DG 3/16) | 3/16" (4.8mm) |
| P69D 1/4(36069DG 1/4) | 1/4" (6.4mm) |

HEMMING & FOLDING FEET 滚边及折押脚



S543 6.0 mm
S544 19.0 mm



SPECIAL PIPPING FEET 特殊带沟押脚

P301C/P31C(31358L/12435R) SERIES



| | |
|-------------------------|---------------|
| P301C 1/8(31358L 1/8) | 1/8" (3.2mm) |
| P301C 3/16(31358L 3/16) | 3/16" (4.8mm) |
| P301C 1/4(31358L 1/4) | 1/4" (6.4mm) |
| P31C 1/8(12435R 1/8) | 1/8" (3.2mm) |
| P31C 3/16(12435R 3/16) | 3/16" (4.8mm) |
| P31C 1/4(12435R 1/4) | 1/4" (6.4mm) |

HINGED STANDARD FEET WITH GUIDE 针送档边押脚

SP18/SP18L SERIES



| | | |
|-----------|------------|---------------|
| SP18 1/32 | SP18L 1/32 | 1/32" (0.8mm) |
| SP18 1/16 | SP18L 1/16 | 1/16" (1.6mm) |
| SP18 1/8 | SP18L 1/8 | 1/8" (3.2mm) |
| SP18 3/16 | SP18L 3/16 | 3/16" (4.8mm) |
| SP18 1/4 | SP18L 1/4 | 1/4" (6.4mm) |
| SP18 5/16 | SP18L 5/16 | 5/16" (8.0mm) |

QUILTER & GUIDE FEET 绗缝导向押脚



S524



R2E



SPK3

SPECIAL TUBE FEET 特殊管状押脚



A225E
S534
55mm

CORDING FEET 缝端押脚

P3 SERIES



- P36N(12435HN)
- P311N(12435N)
- P31(12435W)
- P301N(31358N)
- P301(31358W)
- P36LN(31358HN)
- P36L(31358HW)
- P36LW(31358HXW)

ZIPPER FEET 拉链押脚



P363
40322SH



P363V
165010H



S518N



S518NS



S518L



P361
121950H



P360
121947H

STANDARD FEET 标准押脚



P58N
142058N



P351
54247



P193
19336



P946
121946



P127
127233



160342



S510



SM20 1/32



150789-001

弯针
LOOPER

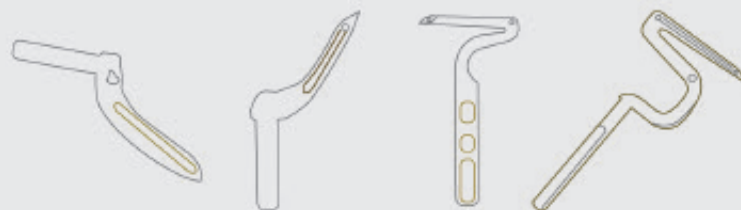



LOOPER for OVERLOCK & INTERLOCK SEWING MACHINES

BROTHER 兄弟 弯针



115069-001
BUTTON SEWER
LOOPER B913



S03536-001
B917



S20626-001
LOWER LOOPER
N11,21,31



19-431
DFB-1404P
DIA.3.15mm



19-431-A
DFB-1404P
DIA.2.5 mm

JUKI 重机 弯针



B1239-372-000
BUTTON SEWER
LOOPER MB-372.3



B2030-380-000
MH-380



B2031-380-000
MH-380



119-99307
LOWER LOOPER
MO-3600,3900

KANSAI-SP 关西 弯针



19-431-N
DFB-1404P DIA.
2.7mm



19-431-S
DFB-1404P DIA.
2.3mm



19-437
RETAINER LOOPER
DFB-1404P

PEGASUS 飞马 弯针



204072
LOWER LOOPER
L32



204949 (11)
UPPER LOOPER
L32



257550
W562



277034
LOWER LOOPER
EX



202408
DCR53-01



202828
M700

LOOPER for OVERLOCK & INTERLOCK SEWING MACHINES

PEGASUS 飞马 弯针



204703
M700

SIRUBA 银箭 弯针



KL25
LOWER LOOPER
737.747.757



KL35A
LOWER LOOPER
737.747.757



LP26
UPPER LOOPER
737.747.757

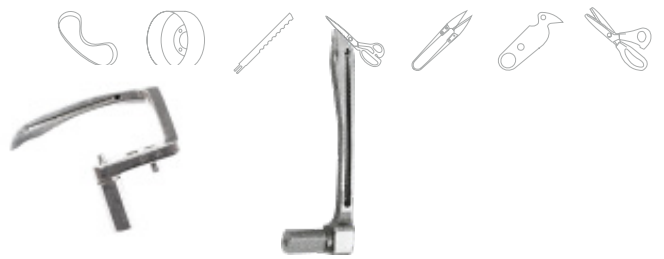

ME28
F007

MT01
C007

YAMATO 大和 弯针



2109300
LOWER LOOPER
AZ8000



3109300
VC2600.2700



针榴
NEEDLE CLAMP

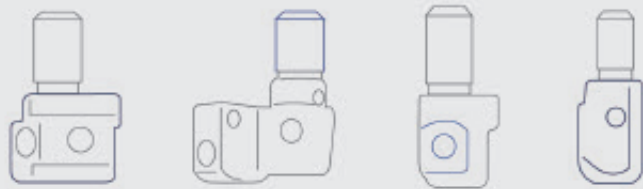

NEEDLE CLAMP for OVERLOCK & INTERLOCK SEWING MACHINES

SIRUBA 银箭 针镗



KG131-E
737D-503F1-04



KG142-E
747D-512M1-24



KG153-E
757-516L1-35



KG155E-E
757-516X2-56



M4240
C007E-W122/CH
W122/CH/UTP/UTR



M4356
F007E-W122
W122/UTG(UTJ)



M4364

PEGASUS 飞马 针镗



208909B92
L32 / M732-38,39



208910
L32 / M732-72,73



209670-92
L52 / M752-01



208905
L52 / M752-13



179630-92
EX5204-01/233K



277022-92
EX5212-02/333K



277027-92
EX3216-02/223K



277028-92
EX3216-03/223K



277029-92
EX3216-04/435K



257518-56
W561-01CB
W562-01CB



257518-64
W561-01CB
W562-01CB



NEEDLE CLAMP for OVERLOCK & INTERLOCK SEWING MACHINES

BROTHER 兄弟 针钳



S20398-001
EF4-N21-22-4



S20404-001
EF4-N31-63-3



S20406-001
EF4-N31-65-5



S21104-001
EF4-N31-92-5



S08711-001
B271-011
B272-011



S08713-001
B271-011
B272-011

JUKI 重机 针钳



118-69005
MO-2504



118-69658
MO-2514-BO6-340
MO-2414N



118-70359
MO-2516-DD4-300



118-70458
MO-2516-FF6-500



121-48607
MO-3904-OE4



121-48706
MO-3914-BE6



121-49803
MO-3916-DD4



121-50306
MO-3916-FF6



121-50603
MO-3943-FBD6



2109100
AZ8003H-04



2109112
AZ8502H-C5

KANSAI-SP 关西 针钳



12-8010-1
W8003D W8103D



12-8020-1
W8003D W8103D



12-8380-0
WX8803D



12-8390-0
WX8803D

NEEDLE CLAMP for OVERLOCK & INTERLOCK SEWING MACHINES
YAMATO 大和 针钳



3209107
VF-2500



3209108
VF-2500



93357
VC-2700



93358
VC-2700





纱剪 剪刀 工具 磨刀石 特殊刀

SCISSORS, THREAD CLIPPERS,
GRINDING STONE, SPECIAL KNIVES



THREAD CLIPPERS TC-100 纱剪



Blade:Steel
Handle:ABS
Weight:14g

- TC-100R(RED)
- TC-100B(BLUE)
- TC-100P(PURPLE)
- TC-100O(ORANGE)
- TC-100T(TURQUOISE)

THREAD CLIPPERS TC-801 纱剪



Blade:Stainless Steel
Handle:ABS
Handle:26g

- TC-801G(GREEN)
- TC-801B(BLUE)
- TC-801Y(YELLOW)
- TC-801O(ORANGE)

THREAD CLIPPERS TC-805B 纱剪



Light weight & Durable
Blade:Steel (Black Oxide Finish)
Handle:PPS
Weight:16g
Color:Matte Black

THREAD CLIPPERS TC-805BS 纱剪



Stainless Steel Blade
Blade:Stainless Steel
Handle:PPS
Weight:16g
Color:Matte Black

THREAD CLIPPERS TC-805 纱剪



Classic Best Seller
Blade:Steel
Handle:Yellow Zinc Plating
Weight:18g
Color:Metallic Gold

RING TYPETHREAD CLIPPERS 指环刀



- TC-RG01Y
- TC-RG02B
- TC-RG02O
- TC-RGMIX



THREAD CLIPPERS TC-808SB 纱剪



Blade:Stainless Steel
 Handle:Aluminum
 Weight:30g



PROFESSIONAL TAILOR SHEAR 专业裁缝剪刀



TC-P300 12" | TC-P280 11" | TC-P260 10" | TC-P240 9" | TC-P220 8"

GOLDEN EAGLE tailor shears use the best quality German special tool steel and finest soft steel composite through special heat treatment for its durable wear-resistant and its long lasting using.

Handle at the top and bottom are different. The bottom curve is small and the top curve is very large, forming almost a straight line, prevents slipping and dropping out of hand.

Thickness of the cutting edge is the same with front and back, even gaps between the edges, comfortable to hold in hand and smooth to use. GOLDEN EAGLE tailor shears is perfectly designed according to ergonomic, coated with durable plastic material for extra comfort and long-time using, specially designed for professional tailors.

PINKING SHEAR TC-230 花边剪刀



STAINLESS SCISSORS TC-S230 不锈钢剪刀



TAGGING GUN 吊牌枪



- TG-88S-O
- TG-88S-B
- TG-88S-R



SKIVING BELL KNIVES 削皮刀 铲皮刀



LEATHER-GE
SIZE:117X114X52.2

BAND KNIVES 钢带刀 运剪刀

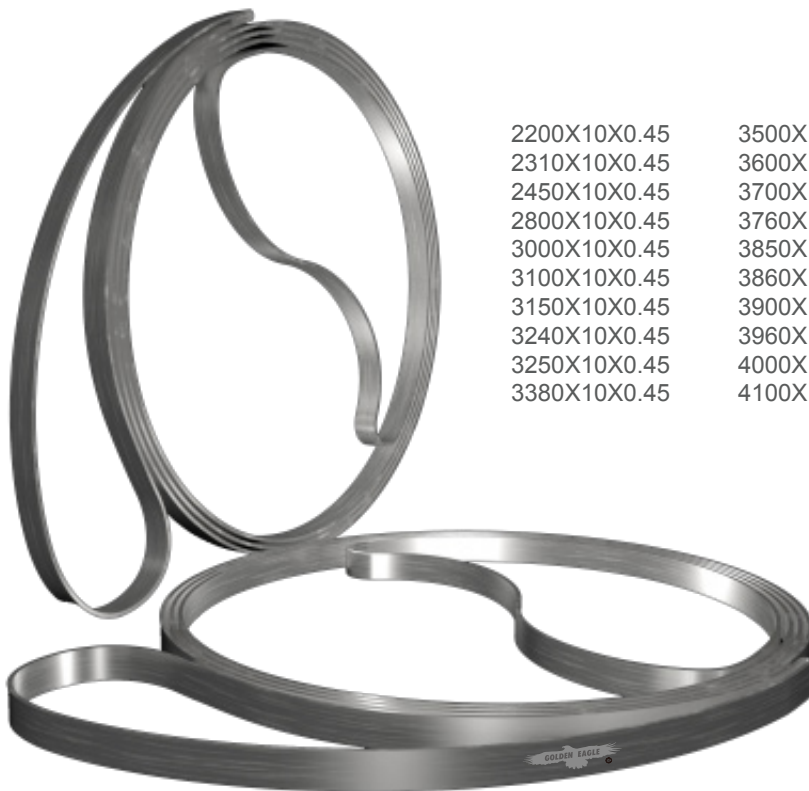

| | | |
|--------------|--------------|--------------|
| 2200X10X0.45 | 3500X10X0.45 | 4120X10X0.45 |
| 2310X10X0.45 | 3600X10X0.45 | 4200X10X0.45 |
| 2450X10X0.45 | 3700X10X0.45 | 4290X10X0.45 |
| 2800X10X0.45 | 3760X10X0.45 | 4500X10X0.45 |
| 3000X10X0.45 | 3850X10X0.45 | 4555X10X0.45 |
| 3100X10X0.45 | 3860X10X0.45 | 4745X10X0.45 |
| 3150X10X0.45 | 3900X10X0.45 | 4920X10X0.45 |
| 3240X10X0.45 | 3960X10X0.45 | 5030X10X0.45 |
| 3250X10X0.45 | 4000X10X0.45 | 5300X10X0.45 |
| 3380X10X0.45 | 4100X10X0.45 | |

ABRASIVE BELTS 砂布带



GS-181C2-1
GS-181C2-2
GS-181C2-5
KM EU 100

HEX WRENCHES



37919

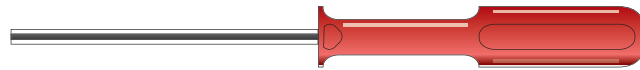

990474-0-10



CLEANING GUN 清洁喷枪

Standard Nozzle



Adjustable Nozzle



CG-500(S)110V
CG-500(S)220V
CG-500(AJ)110V
CG-500(AJ)220V
CG-500(S+AJ)110V
CG-500(S+AJ)220V

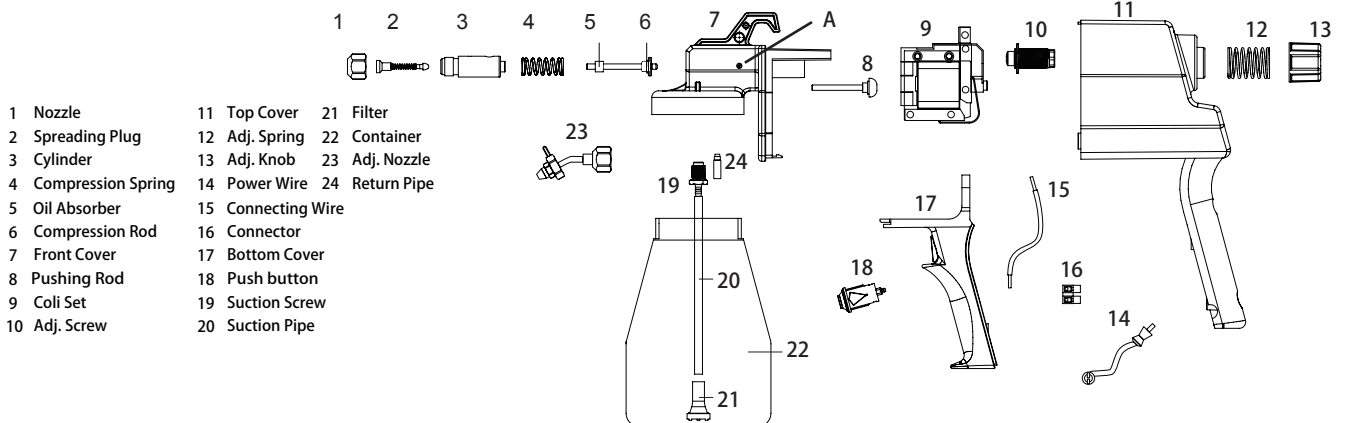



GRINDING STONE-EASTMAN 伊士曼 磨刀石



131C1-12
133C1-12



133C1-25



133C1-11



133C1-14

GRINDING STONE-MAIMIN 磨刀石



381A



330N



525

GRINDING STONE-WOLF 磨刀石



12701
12801



12800



45483

GRINDING STONE-SU LEE 磨刀石



2626-S



2626



26327

GRINDING STONE-NIPPY 磨刀石



416



400/7
T-50
7506-2



513
T-80
7506-1

STONE FEED ROLLER

GRINDING STONE-SUPRENA 磨刀石



M688Z

GRINDING STONE-KM 磨刀石



A-118



S150



R-58

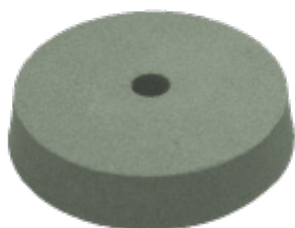

R101J103

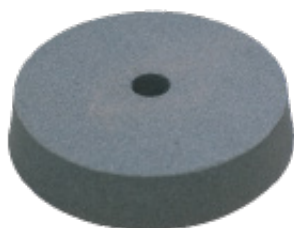

R101E08



R101W05



裁布机零件
CUTTING MACHINE SPARE PARTS

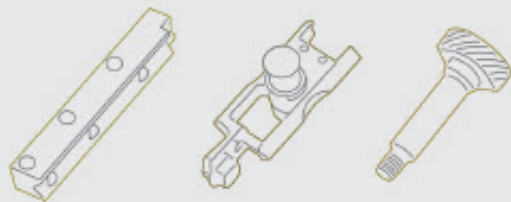

CUTTING MACHINE SPARE PARTS FOR EASTMAN TYPE SERIES

| | |
|-----------|-----------------------------------|
| 4C1-99 | SHARPENER HOLD-DOWN, NUT |
| 4C1-150 | SHARPENER HOLD-DOWN, NUT |
| 4C1-179 | FRONT-TO-REAR BRARING, NUT |
| 4C2-2 | PLATE BOLT, NUT |
| 20C3-38 | FRONT TO REAR BEARING, SCREW |
| 20C3-39 | FRONT TO REAR BEARING, SCREW |
| 20C13-96 | STANDARD-TO-BEARONG, SCREW |
| 24C4 | PLATE, BOLT |
| 4C1-145 | SHAFT, LOCKNUT |
| 4C2-87 | CLUTCH ,NUT |
| 8C5-10 | AUTOMATIC STITCH INSULATION |
| 8C12-4 | LEAD WIRE INSULATION |
| 10C1-41 | FAN ROTOR |
| 12C1-12 | LOADING SPRING, WASHER |
| 12C1-32 | LOCK, WASHER |
| 13C1-9 | TUNING KNOB |
| 18C6-16 | RETAINING RING |
| 22C1-24 | CARRYING HANDLE |
| 30C1-8 | DUST CAP |
| 34C1-51 | CLUTCH, SPRING |
| 47C4-79 | TERMINAL |
| 47C4-80 | TERMINAL |
| 53C7-35 | FAN COVER |
| 73C7-121 | TERMINAL WIRE TUBING |
| 90C1-146 | REAR BEARING HOUSING |
| 90C6-46 | REAR BALL BEARING |
| 254C1 | CABLE TIE 4" |
| 300C12-6 | SCREW, ROUND HEAD |
| 301C8-1 | SCREW, #4-40 X 1/2 FILLISTER HEAD |
| 301C12-3 | SCREW, #8-32 X 3/8 FILLISTER HEAD |
| 305C8-1 | SCREW,BINDING HEAD |
| 305C10-1 | SCREW,BINDING HEAD |
| 597C2-14 | CUTOUT ASSY 60 CYCLE 3600RPM |
| 597C2-15 | CUTOUT ASSY 50 CYCLE 3000RPM |
| 580C1-192 | CUTOUT SWITCH SINGLE SPEED |
| 783C1-3 | GROUNDING WIRE ASS'Y |
| 4C1-111 | OPEARING HANDLE LOCK NUT |
| 4C1-132 | CRANK BELL BEARING LOCK NUT |
| 4C1-190 | LOCK NUT FOR SHAFT |
| 4C2-91 | NUT FOR GUIDE SCREW |
| 4C2-110 | STOP NUT |
| 4C3-8 | GUIDE ADJUSTMENT NUT |
| 11C12-92 | SHAFT FOR BALL BEARING |
| 12C1-21 | SHAKEPROOF WASHER |
| 12C1-24 | KNIFE LOCK WASHER |
| 12C10-2 | WASHER |
| 12C15-14 | GUIDE WASHER |
| 12C15-53 | CONNECTING ROD WASHER |
| 15C13-23 | STUD,UPPER |
| 15C13-34 | STUD, LOWER L.H. MOUNTING |
| 15C13-39 | STUD, LOWER R.H. MOUNTING |
| 17C4-6 | WRIST PIN |
| 18C6-79 | LOCK RING |
| 18C6-80 | O-RING |
| 20C5-17 | CONNECTING ROD CLAMP SCREW |





CUTTING MACHINE SPARE PARTS FOR EASTMAN TYPE SERIES

| | |
|-----------|---------------------------------------|
| 20C12-62 | FRONT HOUSING PLUG SCREW |
| 20C12-79 | SCREW FOR HANDLE BRACKET |
| 24C1-3 | KNIFE LOCK BOLT |
| 34C10-142 | SPRING FOR CAPACITOR |
| 52C5-235 | SWITCH PLATE (SINGLE-SPEED) |
| 53C6-2 | OILER TUBE COVER |
| 53C11-91 | CAPACITOR COVER |
| 54C4-32 | WRIST PIN PLUG |
| 62C1-140 | HANDLE BRACKET |
| 71C3-18 | FRONT BALL BEARING RETAINER |
| 73C7-203 | OIL TUBE , CLEAR |
| 73C7-204 | OILER TUBE |
| 85C1-45 | CRANK 5 - 1-1/2" STROKE |
| 90C6-38 | FRONT BALL BEARING |
| 91C4-25 | RIVET CROSSHEAD |
| 191C1-21 | CROSS HEAD FELT PAD |
| 191C1-38 | WRIST PIN FELT PAD |
| 191C1-42 | OIL FELT WICKING, LONG |
| 191C1-43 | OIL FELT WICKING, SHORT |
| 191C1-45 | OIL FELT WICKING .187DIA X .44 |
| 201C1-11 | EYELET |
| 300C3-2 | SCREW |
| 302C8-2 | SCREW, FLAT HEAD #4-40 X 3/4 |
| 302C10-4 | SCREW, #6-32 X 5/16 FLAT HEAD |
| 307C18-1 | SCREW |
| 308C12-1 | SCREW, #8-32 X 3/8 SOCKET HEAD |
| 308C14-1 | GUIDE HOLD DOWN SCREW |
| 309C15-5 | GUIDE ADJUSTMENT SCREW |
| 525C1-5 | L.H. & R.H. GUIDES 1-1/2 STROKE |
| 531C1-53 | OPERATING HANDLE |
| 579C2-17 | CROSS HEAD (W/ WRIST,PIN,WASHER,BOLT) |
| 580C1-198 | SWITCH-SINGLE-SPEED-1&3-PHASE |
| 607C1-35 | OILING DEVICE |
| 664C1-4 | CONNECTING ROD 1 1/2 STROKE |
| 706C1-4 | CAPACITOR 629 110V |
| 706C1-5 | CAPACITOR 629 220V |
| 4C1-149 | NUT, ELASTIC |
| 4C1-161 | NUT, SELF LOCK |
| 4C2-112 | L.H. NUT FOR SCREW SHAFT |
| 4C2-113 | R.H. NUT FOR SCREW SHAFT |
| 5C5-16 | COLLAR, LOWER |
| 11C12-54 | SHAFT FOR CAM |
| 12C15-57 | SPRING WASHER FOR RELEASE LEVER |
| 12C15-69 | WASHER FOR LOCK BRACKET |
| 12C15-74 | WASHER, FLAT |
| 12C15-91 | THRUST WASHER, UPPER NUT |
| 17C15-106 | ROLL PIN FOR COLLAR |
| 20C4-17 | PRESSURE FOOT LEVER SCREW |
| 20C12-13 | CAM SHAFT SPRING SCREW |
| 20C12-113 | SCREW FOR LATCH |
| 20C12-117 | SCREW FOR PRESSURE FOOT SHOE |
| 20C12-156 | SCREW FOR RELEASE LEVER |
| 20C12-137 | SCREW FOR KNIFE GUARD LOCK |
| 22C3-2 | LIFT HANDLE FOR KNIFE GUARD LOCK |
| 34C1-20 | TENSION SPRING |

CUTTING MACHINE SPARE PARTS FOR EASTMAN TYPE SERIES

| | |
|-----------|--|
| 34C8-12 | SPRING FOR PRESSURE FOOT LOCK |
| 34C10-179 | SPRING FOR PRESSURE FOOT LEVER |
| 34C10-107 | SPRING FOR LATCH |
| 53C11-72 | COVER FOR CAM |
| 53C11-103 | VINYL COVER FOR HANDLE |
| 55C4-49 | SPACER FOR KNIFE GUARD LOCK BRACKET |
| 68C1-192 | PRESSURE FOOT SHOE, ALL STROKES |
| 71C3-15 | THRUST BALL BEARING |
| 86C7-34 | CAP FOR TUBE |
| 90C4-47 | BEARING FOR CAM SHAFT |
| 97C3-35 | LATCH FOR CAM |
| 147C1-26 | EXTENSION FOR SCREW SHAFT |
| 171C1-16 | LOCK (ONLY) FOR PRESSURE FOOT |
| 300C10-1 | SCREW, #6-32 X 3/16 ROUND HEAD |
| 300C10-4 | SCREW, #6-32 X 3/8 ROUND HEAD |
| 302C10-8 | SCREW, #6-32 X 3/4 FLAT HEAD |
| 309C15-7 | SET SCREW FOR CAM |
| 553C1-7 | PRESSURE FOOT LOCK BRACKET COMPLETE |
| 553C1-8 | PRESSURE FOOT LOCK BRACKET ONLY |
| 605C1-36 | PRESSURE FOOT ROD 7"-8" KNIFE |
| 605C1-37 | PRESSURE FOOT ROD 9"-10" KNIFE |
| 621C1-7 | RELEASE LEVER WITH CAM |
| 683C1-17 | PREAAURE FOOT LEVER |
| 713C4-4 | SCREW SHAFT W/EXTENSION R&H HEAD |
| 713C4-5 | NUTS 5-8"(713C-4) / NUTS 9-10"(713C-5) |
| 732C1-11 | SHARPENER HOUSING W/BUSHING, TUBES ONLY |
| 732C1-12 | 5"- 8" KNIFE(732C1-11) / 9"- 10" KNIFE(732C1-12) |
| 65C1-77 | ROD FOR PRESS FOOT 5"-8" |
| 65C1-75 | ROD FOR PRESS FOOT 9"&10" |
| 11C12-95 | SCREW SHAFT ONLY 5" - 8" |
| 11C12-96 | SCREW SHAFT ONLY 9" -10" |
| 4C2-85 | R.H. FOLLOWER NUT |
| 4C2-86 | L.H. FOLLOWER NUT |
| 11C12-58 | R.H. SQUARE SHAFT 5"-8" KNIFE |
| 11C12-59 | R.H. SQUARE SHAFT 9"-10" KNIFE |
| 11C12-56 | L.H. SQUARE SHAFT 5"-8" KNIFE |
| 11C12-57 | L.H. SQUARE SHAFT 9"-10" KNIFE |
| 11C12-64 | SHAFT FOR CRANK |
| 12C11-74 | THRUST WASHER |
| 12C15-29 | THRUST WASHER |
| 12C15-30 | THRUST WASHER FOR BOTTOM PLATE |
| 17C15-78 | PIN FOR BELL CRANK |
| 17C15-103 | ROLL PIN FOR PUSH ROD |
| 17C15-113 | SPREADER PIN |
| 18C6-81 | RETAINING RING FOR SHAFT |
| 18C6-26 | RETAINING RING FOR BELL CRANK |
| 34C10-89 | SPRING FOR BELL CRANK |
| 55C4-41 | SPACER BELL CRANK |
| 62C16-151 | SHARPENER HOUSING (ONLY) |
| 65C6-75 | PUSH ROD |
| 71C1-10 | OIL RETAINER-IDLER GEAR |
| 73C7-46 | TUBE FOR SQUARE SHAFT 5"-8' KNIFE |
| 73C7-47 | TUBE FOR SQUARE SHAFT 9"-10" KNIFE |
| 73C7-48 | TUBE FOR SCREW SHAFT 5"-8" KNIFE |





CUTTING MACHINE SPARE PARTS FOR EASTMAN TYPE SERIES

| | |
|-----------|------------------------------------|
| 73C7-49 | TUBE FOR SCREW SHAFT 9"-10" KNIFE |
| 79C12-163 | BOTTOM PLATE, SHARPENER HOUSING |
| 85C3-6 | CRANK BELL (ONLY) |
| 87C3-8 | SPIRAL GEAR |
| 87C3-44 | SPUR GEAR |
| 87C3-53 | GEAR AND SHAFT |
| 90C4-29 | BEARING FOR DRIVE SHAFT (LOWER) |
| 90C4-33 | BEARING FOR GEAR |
| 90C4-34 | BEARING FOR BELL CRANK |
| 90C4-42 | BEARING FOR DRIVE SHAFT |
| 90C4-48 | BEARING FOR DRIVE SHAFT (UPPER) |
| 90C4-58 | BEARING FOR SCREW SHAFT |
| 90C6-24 | BALL BEARING FOR CRANK |
| 142C1-7 | KEY FOR GEAR. |
| 300C7-1 | SCREW, #4-36 X 1/8 ROUND HEAD |
| 302C10-6 | SCREW, #6-32 X 1/2 FLAT HEAD |
| 302C12-3 | SCREW, #8-32 X 3/8 FLAT HEAD |
| 584C2-3 | BELLCRANK WITH PIN & BEARING(ONLY) |
| 584C3-16 | BELLCRANK COMPLETE WITH LEVER |
| 602C1-9 | DRIVER PULLEY WITH DRIVER |
| 627C1-10 | IDLER GEAR & BUSHING |
| 716C1-12 | DRIVER SHAFT WITH GEAR |
| 727C1-6 | OIL PAD & HOLDER |
| 17C15-82 | RIVET |
| 300C7-2 | SCREW, #4-36 X 3/16 ROUND HEAD |
| 1C13-13 | NUT |
| 53C11-109 | VINYL COVER FOR CRANK |
| 4C1-189 | JAM NUT,#8-32 |
| 4C2-63 | NUT FOR SHARPENER SHOE SCREW |
| 12C15-93 | WASHER, SHOE |
| 20C6-25 | ADJUSTING SCREW |
| 20C12-143 | SCREW FOR CLAMPING ARM |
| 20C12-153 | SCREW FOR SHARPENER SHOE |
| 21C14-14 | BUSHING FOR SHARPENER SHOE |
| 34C10-45 | SPRING FOR PULLEY SLIDE |
| 34C10-123 | SPRING FOR ARM |
| 34C10-148 | L.H. SHARPENER SHOE SPRING |
| 34C10-149 | R.H. SHARPENER SHOE SPRING |
| 35C7-28 | CLAMPING ARM FOR SHOE |
| 53C4-78 | GEAR COVER |
| 54C4-35 | OIL HOLE PLUG |
| 62C6-31 | BRACKET, LOWER GEAR |
| 70C4-32 | GUIDE BACK OF STANDARD |
| 79C12-219 | WEAR PLATE |
| 87C3-50 | GEAR ON SCREW SHAFT |
| 87C5-13 | INTERMEDIATE GEAR |
| 90C4-51 | BEARING FOR SCREW SHAFT |
| 90C4-59 | BEARING FOR SHAFT EXTENSION |
| 147C1-28 | R.H. SHAFT EXTENSION |
| 147C1-29 | L.H. SHAFT EXTENSION |
| 152C1-19 | FRONT PULLEY FOR BELT |
| 209C1 | NEOPRENE BAND FOR PULLY |
| 300C7-3 | SCREW, #4-36 X 1/4 ROUND HEAD |
| 300C10-2 | SCREW, #6-32 X 1/4 ROUND HEAD |

CUTTING MACHINE SPARE PARTS FOR EASTMAN TYPE SERIES

| | |
|------------|---|
| 300C10-6 | SCREW, #6-32 X 1/2 ROUND HEAD |
| 301C7-2 | SCREW, #4-36 X 3/16 FILLISTER HEAD |
| 301C10-3 | SCREW, #6-32 X 3/8 FILLISTER HEAD |
| 309C12-2 | STOP SCREW, L.H. SHOE |
| 712C1 | R.H. SLIDE WITH PULLEY |
| 712C1-1 | L.H. SLIDE WITH PULLEY |
| 715C1-19 | LOWER GEAR BRACKET WITH COVER,SCREW,PLATE 5 - 13" |
| 715C1-23 | LOWER GEAR BRACKET (COMPLETE) |
| 728C1-5 | STABILIZER ASSEMBLY |
| 743C1-28 | R.H. PRE-SET SHARPENER SHOE (ONLY) |
| 743C1-29 | L.H. PRE-SET SHARPENER SHOE (ONLY) |
| 820C1-7 | L.H. COMPLETE SHOE ASSEMBLY, |
| 820C1-8 | R.H. COMPLETE SHOE ASSEMBLY, |
| 12C1-35 | LOCK WASHER, #8 . |
| 17C1-4 | TAPER PIN #0 X 3/4 |
| 17C6-9 | HINGE PIN |
| 20C5-12 | CLAMP SCREW FOR ROLLERS |
| 20C12-19 | KNIFE SLIDE SCREW |
| 20C13-51 | HINGE PIN CLAMP SCREW |
| 34C1-57 | PLATE WING TENSION SPRING |
| 60C1-55 | PLATE WING (FOR SMALL PLATES) |
| 60C1-56 | PLATE WING (FOR LARGE PLATES) |
| 79C4-12 | THROAT PLATE WITH SCREW AND PIN |
| 213C1-1 | FIBRE SHIM |
| 505C3-223 | SMALL PLATE BASE COMPLETE 5"-8" KNIFE |
| 505C3-224 | LARGE PLATE BASE COMPLETE 9"-13" KNIFE |
| 528C1-116 | STANDARD (COMPLETE W/SLIDER,THROAT PLATE) |
| 528C1-121 | 10" KNIFE(528C1-116) / 8" KNIFE(528C1-121) |
| 532C2-5 | RUBBER MOUNTED ROLLER (COMPLETE) |
| 619C1-31 | ROLLER SHELL (COMPLETE) |
| 643C1-43 | KNIFE SLIDE (COMPLETE WITH SCREWS) 8" |
| 643C1-47 | KNIFE SLIDE (COMPLETE WITH SCREWS) 10" |
| 529C1-8 | KNIFE BOLT WRENCH |
| 95C5-3 | ALLEN WRENCHFOR SHOE SET SCREW |
| 242C2-2 | BEARING GREASE |
| 162C2 | OIL CAN |
| 81C1-2 | SLOT CLEANSE |
| 181C2-2 SP | ABRASINE BELTS |
| 508C1-100 | TREMINAL BLOCK |
| 523C1-100 | ATTACHMENT PLUG |





CUTTING MACHINE SPARE PARTS FOR EASTMAN TYPE SERIES

Single-Phase Motor Assemblies

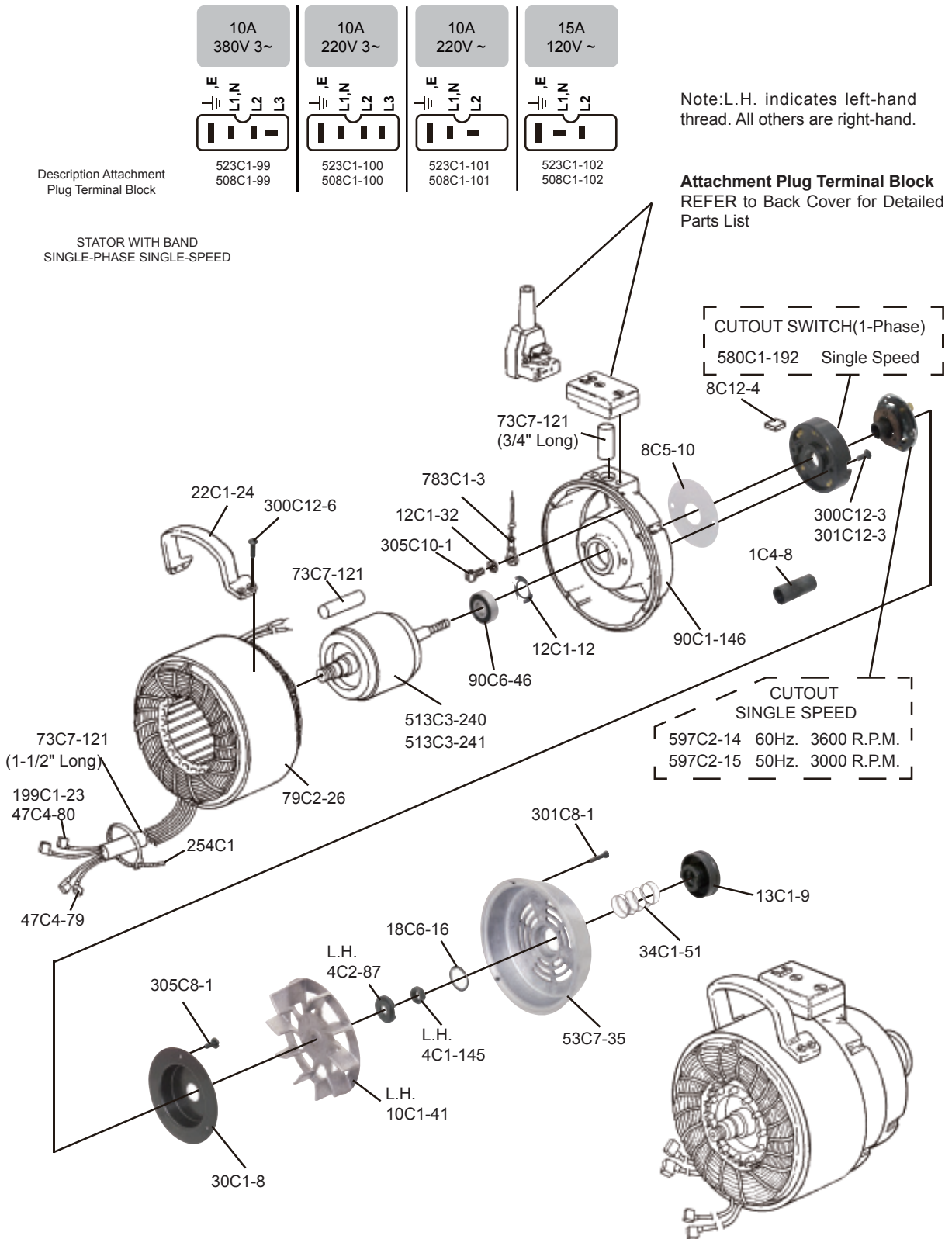

CUTTING MACHINE SPARE PARTS FOR EASTMAN TYPE SERIES

Front Bearing Housing with Oiler Assembly

Note: Certain 220 volt machines will use these capacitors. Please check the capacitor number on label of your machine to order.

| | |
|----------|----------|
| 706C1-4 | 110 Volt |
| 706C1-5 | 220 Volt |
| 706C1-13 | 110 Volt |
| 706C1-18 | 220 Volt |

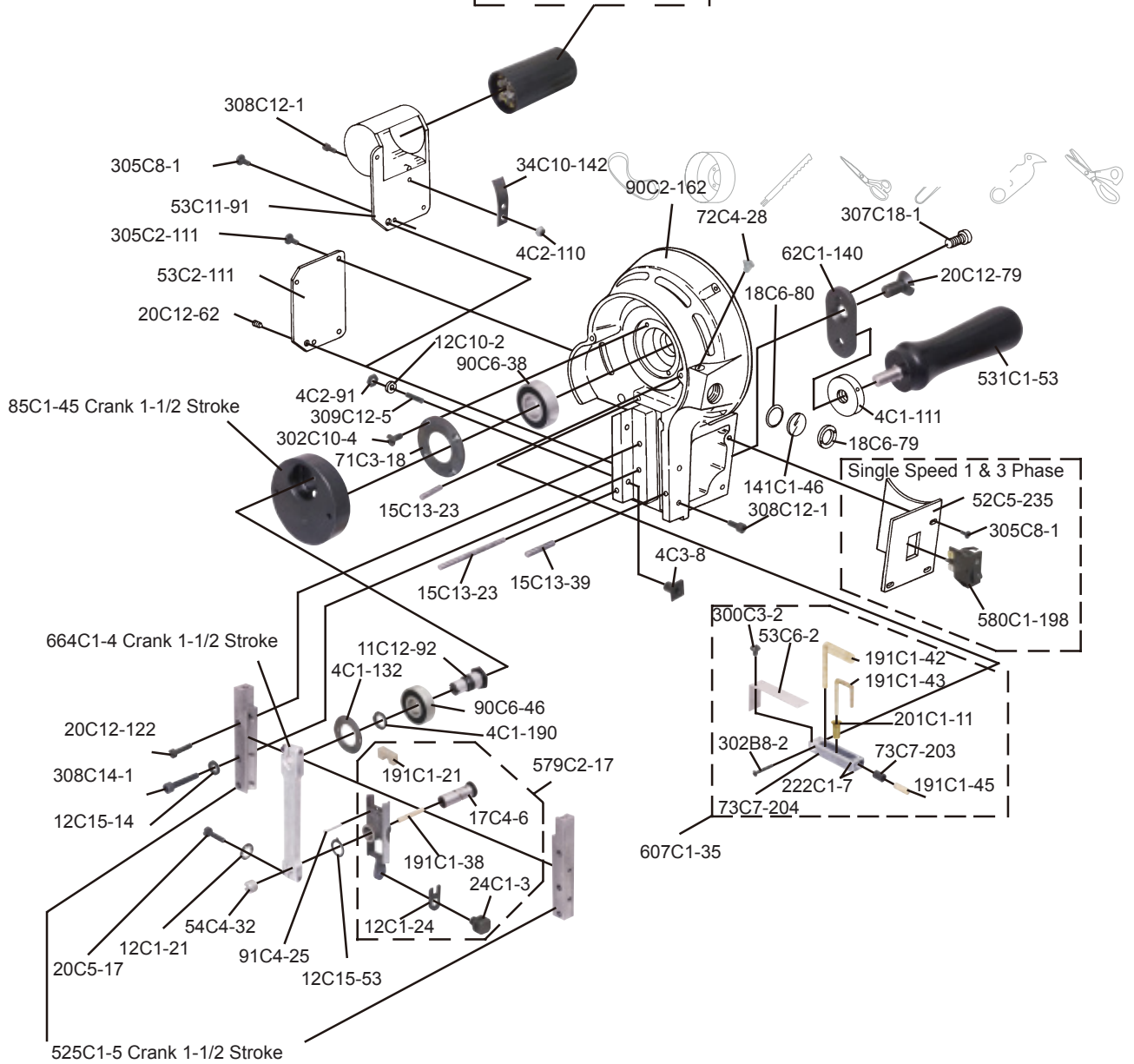

Notes: L.H. indicates left-hand thread. All others are right-hand.

Slip large lug over switch before replacing switch base. Secure switch to base tightly to ensure positive ground.



CUTTING MACHINE SPARE PARTS FOR EASTMAN TYPE SERIES

Sharpener Housing Assembly

Note:
L.H. indicates left-hand thread.
All others are right-hand.

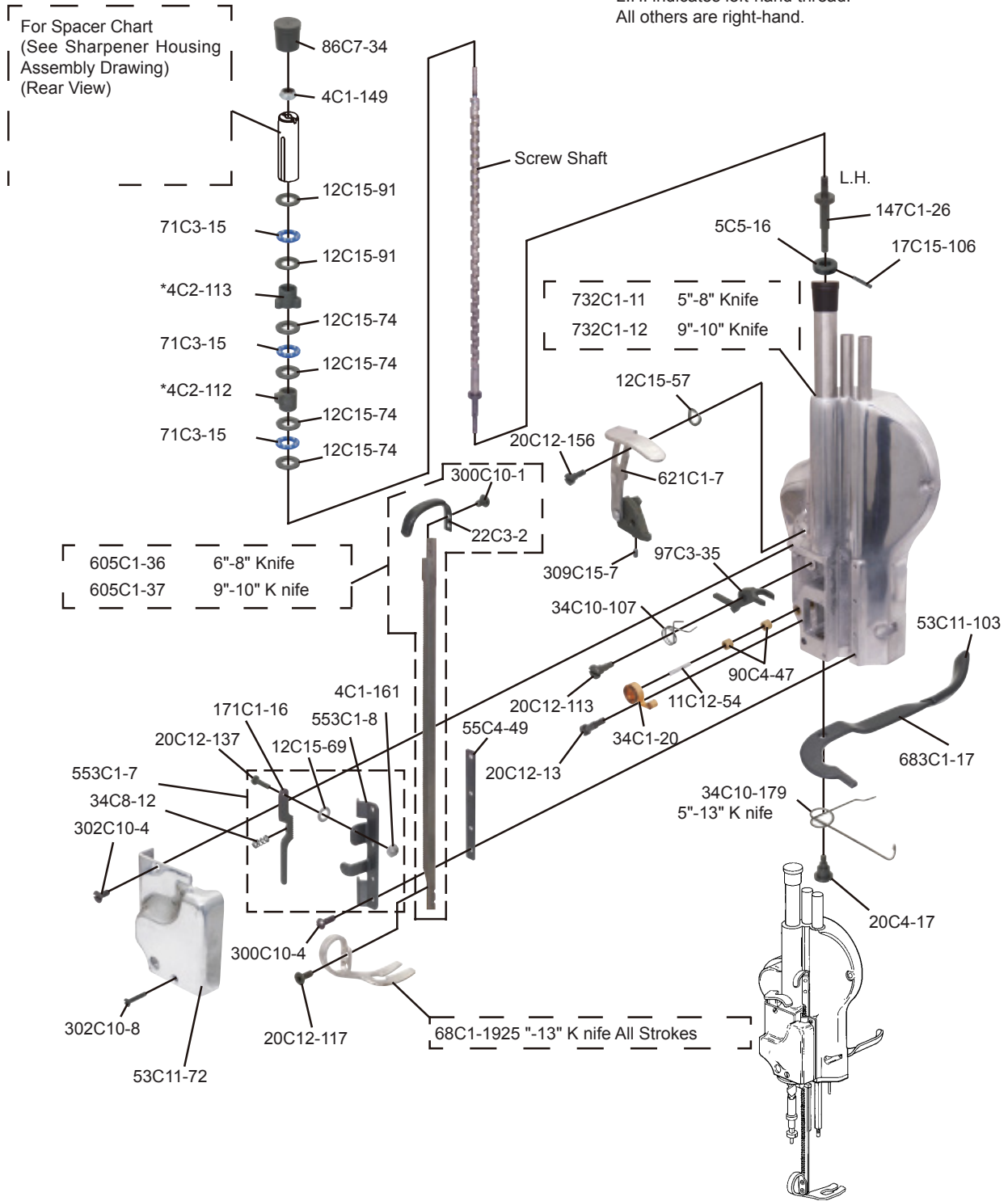

CUTTING MACHINE SPARE PARTS FOR EASTMAN TYPE SERIES

Sharpener Housing Assembly

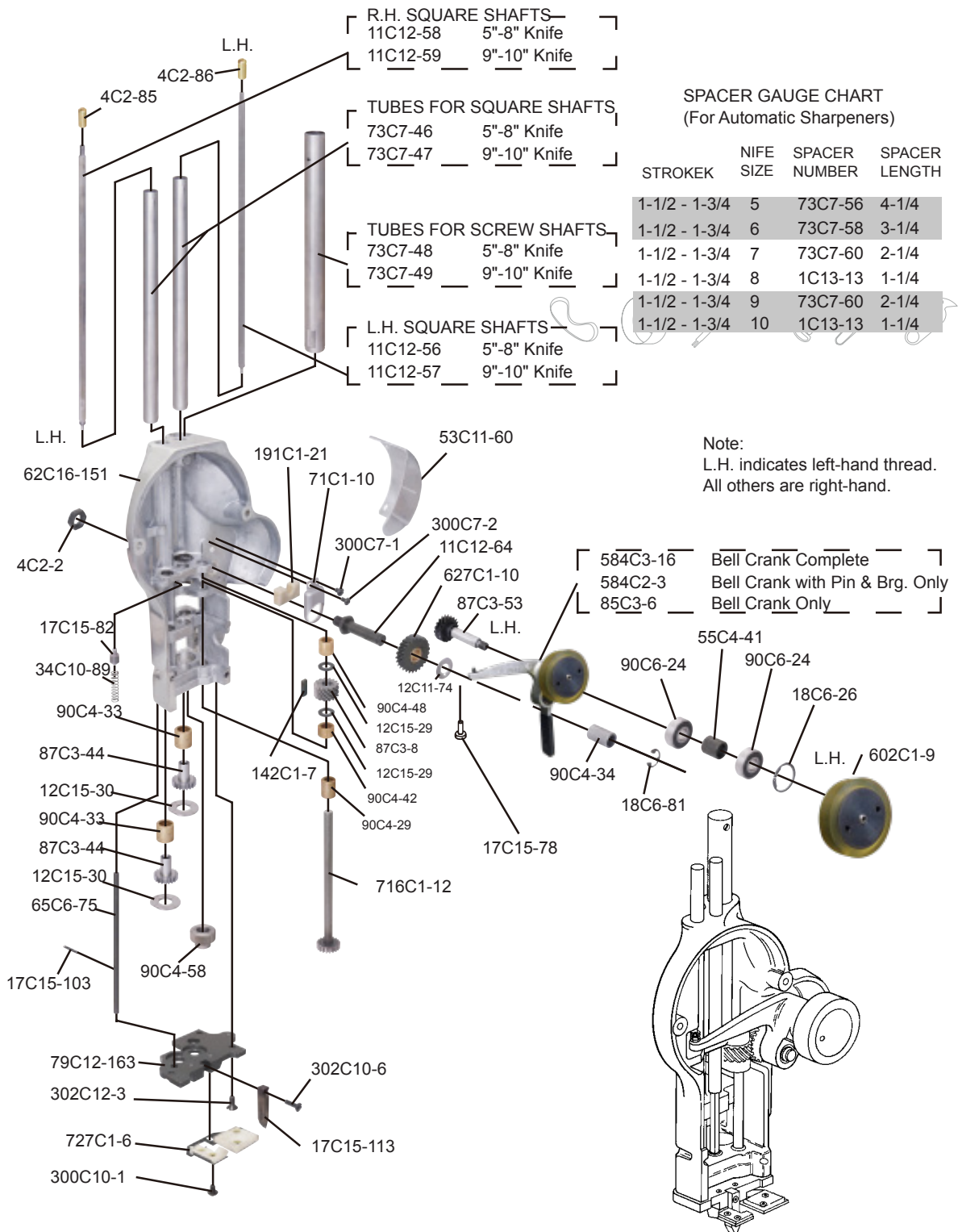



CUTTING MACHINE SPARE PARTS FOR EASTMAN TYPE SERIES

Lower Gear Bracket Assembly

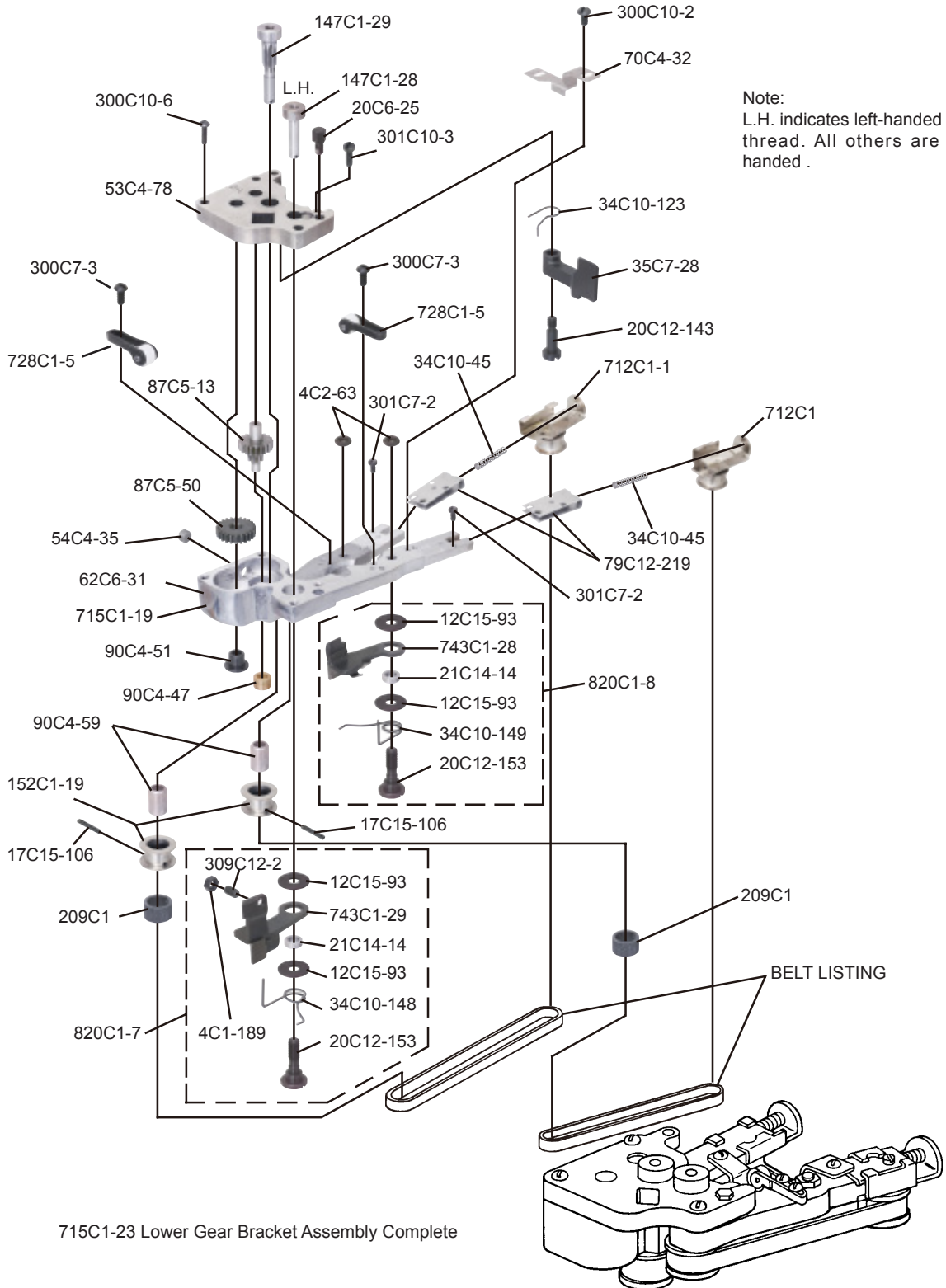

CUTTING MACHINE SPARE PARTS FOR EASTMAN TYPE SERIES

Standard and Baseplate Assembly

STANDARDS
COMPLETE W/SLIDES
528C1-121 8" Standard
528C1-116 10" Standard

KNIFE SLIDES
643C1-43 8" Knife
643C1-47 10" Knife

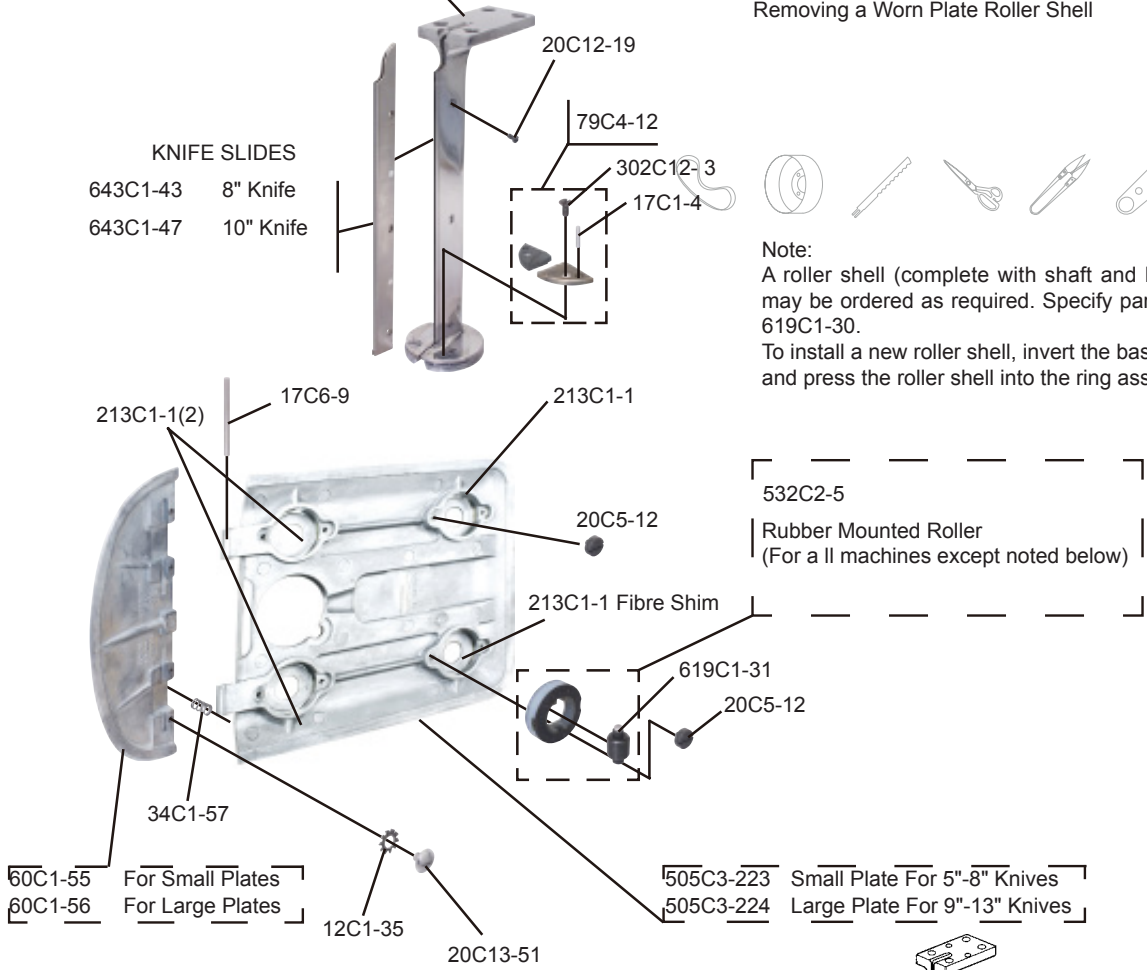

INSTRUCTIONS FOR REMOVING WORN PLATE ROLLER SHELL

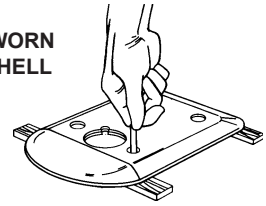

Removing a Worn Plate Roller Shell



Note:
A roller shell (complete with shaft and bearings) may be ordered as required. Specify part number 619C1-30.
To install a new roller shell, invert the baseplate and press the roller shell into the ring assembly.

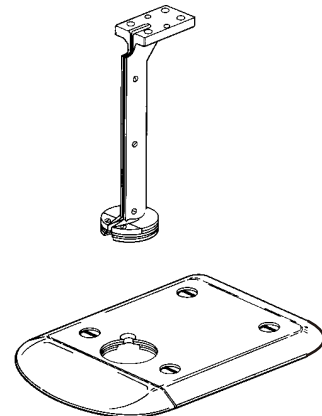



CUTTING MACHINE SPARE PARTS FOR KM TYPE SERIES

| | |
|---------|-----------------------------|
| M-1 | Capacitor-Stator |
| M-2 | Carrying Handle Screws |
| M-3 | Rotor Fan |
| M-4 | Rotor With Shaft |
| M-6 | Dust Cap Screw |
| M-7 | Rear Bearing Housing |
| M-8 | Dust Cap |
| M-9 | Turning Knob |
| M-13 | Front to Rear Bearing Nut |
| M-14 | Front to Rear Bearing Screw |
| M-20 | Switch |
| M-21 | Clutch Spring |
| M-22 | Retaining Ring |
| M-23 | Rear Ball Bearing |
| M-24 | Spring Washer |
| M-25 | Clutch Nut |
| M-26 | Shaft Lock Nut |
| M-27 | Crank |
| M-28 | Crank Ball Bearing |
| M-29 | Crank Ball Bearing Lock Nut |
| M-30 | Screw for Brg Shaft |
| M-31 | Shaft for Ball Bearing |
| M-32 | Oil Pad Holder |
| M-33 | Oil Felt |
| M-34 | Oil Tank |
| M-34C | Set Oil Tank |
| M-35 | Oil Tank Cap |
| M-36 | Connec ting Rod |
| M-37 | Shakeproof Washer |
| M-38 | Connec Ting Rod Clamp Screw |
| M-39 | Wrist Pin |
| M-40 | Wrist Pin Plug |
| M-41 | Knife Lock Washer |
| M-42 | Nuts for Guide Screw |
| M-43 | Guide Washer |
| M-44 | Connecting Rod Washer |
| M-45 | Guide Adjusting Screw |
| M-46 | Guide Adjusting Nut |
| M-47 | Guide Lock Screw |
| M-48 | R.H.Guide |
| M-49 | L.H.Guide |
| M-48/49 | Guide |
| M-50 | Cross Head |
| M-51 | Knife Lock Bolt |
| M-52 | Terminal Block Screw |
| M-53 | Ground Clip Screw |
| M-54 | Set Screw |
| M-55 | Front Bearing Housing |
| M-56 | Sharpener Hold Down Screw |
| M-57 | Retainer Screw |
| M-58 | Oil Pad Holder Screw |
| M-59-S | Guide Hold Down Screw(S) |
| M-59-L | Guide Hold Down Screw(L) |
| M-60 | Lower Sharpener |

CUTTING MACHINE SPARE PARTS FOR KM TYPE SERIES

| | |
|---------|------------------------------|
| M-60-R | Hold down Nut R |
| M-61L | Stud Lower L.H.Mountaing(L) |
| M-61R | Stud Lower L.H.Mountaing(R) |
| M-63 | Standard-to-Bearing Screw |
| M-64 | Front Ball Bearing |
| M-65 | Front Ball Bearing Retainer |
| M-66 | Ground Clip |
| M-67 | Attachment Plug Complete(3P) |
| M-68 | Terminal Block Complete(3P) |
| M-69 | Attachment Plug (Complete) |
| M-70 | Terminal Block (Complete) |
| M-71 | Terminal Sleeve |
| M-72 | Terminal Contact with Pin |
| M-73 | Operating Handle |
| M-74 | Lock Nut |
| M-75 | Switch Cover Screw |
| M-76 | Switch Cover |
| M-77S | GKM-AU-J-077S |
| M-77L | GKM-AU-J-077L |
| M-78 | Plate Complete |
| M-80 | Rubber Mounted Roler |
| M-80C | Roller |
| M-80R | Rubber |
| M-81 | Hinge Pin Short |
| M-82 | Hinge Pin Clamp Screw |
| M-83 | Plate Wing Tension Spring |
| M-84 | Knife Slide Screw |
| M-85 | Standard(8") |
| M-85 | Standard(10") |
| M-85 | Standard(13") |
| M-85 | Standard(6") |
| M-85 | Standard(7") |
| M-86 | Knife Slide(8") |
| M-086 | Knife Slide(10") |
| M-87 | Screw for Throat Plate |
| M-88 | Throat Plate |
| M-89 | Lock Washer |
| M-90-S | Plate Screw |
| M-90-N | Plate Nut |
| M-92 | Cap for Tube |
| M-93 | Driving Shaft(6"~8") |
| M-93 | Driving Shaft(9"~10") |
| M-93 | Driving Shaft(13") |
| M-94 | Hand Follower(6"~8") |
| M-94 | Hand Follower(9"~10") |
| M-94 | Hand Follower(13") |
| M-96 | Screw for Latch |
| M-97 | Shaft for Cam |
| M-98 | Cam Shaft Spring Screw |
| M-99 | Pres Foot Lock Bracket Screw |
| M-100-S | Screw for Cover(S) |
| M-100-L | Screw for Cover(L) |
| M-101 | Cover Over Cam |
| M-102 | Collar for Screw Shaft |





CUTTING MACHINE SPARE PARTS FOR KM TYPE SERIES

| | |
|----------|--------------------------------|
| M-104-R | Nut for Screw ShaftR.H |
| M-104-L | Nut for Screw Shaft L.H |
| M-105 | Washer for Screw Shaft L.H |
| M-106 | Screw shaft (6"~8") |
| M-106 | Screw shaft (9",10") |
| M-106 | Screw shaft(13") |
| M-107 | Spacer tube(6") |
| M-107 | Spacer tube(7",13") |
| M-107 | Spacer tube(8",9",10") |
| M-108 | Stop Nut for Screw Shaft |
| M-109 | Spring for Pressure Foot Lock |
| M-110 | Spring for Lateh |
| M-111 | Cam Spring |
| M-112 | Pressure Foot Rod(6") |
| M-112 | Pressure Foot Rod(7") |
| M-112 | Pressure Foot Rod(8") |
| M-112 | Pressure Foot Rod(10") |
| M-112 | Pressure Foot Rod(13") |
| M-113 | Screw for Pressure Foot Shoe |
| M-114 | Pressure Foot Lever |
| M-115 | Pressure Foot Lever Screw |
| M-116 | Spring for Pressure Foot Lever |
| M-117 | Set Screw for Cam |
| M-118-C | Cam |
| M-118-L | Release Lever |
| M-118-S | Screw for cam |
| M-119-S | Lock Screw for Releast Lever |
| M-119-SW | Spring Washer |
| M-119-W | Washer |
| M-120 | Lock(only) Pressure Foot |
| M-121-S | Screw for Pres Ft Lock |
| M-121-N | Nut for Pres Ft Lock |
| M-122 | Pressure Foot Lock Bracket |
| M-123 | Slide for Pressure Foot Rod |
| M-123-2 | Washer Slide for presser foot |
| M-124 | Latch for Cam |
| M-125 | Pressure Foot Shoe |
| M-126 | Spring for Bell Crank |
| M-127 | Sharpener Housing(8") |
| M-127 | Sharpener Housing(13") |
| M-128 | Bottom Plate Screw |
| M-129 | Bottom Plate |
| M-130 | Oil Pad & Holder |
| M-131 | Screw for Oil Pad |
| M-132 | Bell Crank With Pim & Bushing |
| M-133 | Screw for Cover |
| M-134 | Cover for Driver |
| M-135 | Right Hand Follower Nut |
| M-136 | R.H.Square Shaft(6"~8") |
| M-136 | R.H.Square Shaft(9",10") |
| M-136 | R.H.Square Shaft(13") |
| M-136-S | R.H.Square Shaft Screw |
| M-137 | Left Hand Follower Nut |
| M-138 | L.H.Square Shaft(6"~8") |

CUTTING MACHINE SPARE PARTS FOR KM TYPE SERIES

| | |
|---------|--------------------------------|
| M-138 | L.H.Square Shaft(9",10") |
| M-138 | L.H.Square Shaft(13") |
| M-138-7 | |
| M-138-W | L.H.Square Shaft Washer |
| M-139 | Push Rod |
| M-140 | Roll Pin for Push Rod |
| M-141 | Driver Shaft With Gear |
| M-142 | Screw for Spreader Pin |
| M-143 | Spreader Pin |
| M-144 | Gear & Shaft |
| M-145 | Bearing for Gear |
| M-146 | Driver Pulley(Set) |
| M-148 | Spur Gear |
| M-149 | Ball Bearing for Crank |
| M-150 | Retaining Ring |
| M-151 | Thrust Washers for Spiral Gear |
| M-152 | Lock Nut for Crank Shaft |
| M-153 | Shaft for Crank |
| M-154 | Washer for Crank Shaft |
| M-155 | Lock Ring for Ball Bearing |
| M-156 | Idler Gear With Bushing |
| M-156-1 | Bushing of Idler Gear |
| M-157 | L.H.Spiral Gear With Key |
| M-158 | Screw for Gear Cover |
| M-159 | Screw for Gear Cover |
| M-160 | Grease Plug |
| M-161 | Screw for Stabilizer |
| M-162 | Lower Gear Bracket |
| M-162-M | Lower gear bracke |
| M-163 | Screw for Slide Pulley |
| M-164 | Lower Gear Bracker Gear Cover |
| M-165-N | Adjusting Nut |
| M-165-S | Adjusting Screw |
| M-166 | Gear on Screw Shaft |
| M-167 | Intermediate Gear |
| M-168 | Bushing for shoe |
| M-169 | GKM-AU-J-169 |
| M-170 | GKM-AU-J-170 |
| M-171 | Set Screw for Sharpener Shoe |
| M-172 | Stabilizer |
| M-173 | Standard Guide(6"~7") |
| M-173 | Standard Guide(8"~10") |
| M-175 | Screw for Guide Back |
| M-176 | R.H.Slide With Pulley |
| M-177 | L.H.Slide With Pulley |
| M-178 | Neoprene Band |
| M-179 | Front Pulley for Belt |
| M-180 | Roll Pin for Pulley |
| M-181 | Spring for Pulley Slide |
| M-182 | Screw for Clamping Rrm |
| M-183 | Clamping Arm for Shoe |
| M-184 | Nut for Sharpener Shoe Screw |
| M-185 | Screw for Sharpener Shoe |
| M-186-R | R.H.Sharpener Shoe Spring |





CUTTING MACHINE SPARE PARTS FOR KM TYPE SERIES

| | |
|---------|-----------------------------|
| M-187-L | L.H.Sharpener Shoe Spring |
| M-188 | Spring for Arm |
| M-189 | Abrasive Belts |
| M-190 | Electric Corde Complete |
| M-191 | Knife |
| M-192 | Knock pin for Throat Plate |
| M-194 | Knife Bolt Wrench |
| M-195 | Screw Driver |
| M-198 | Bearing Grease |
| M-199 | Oiler |
| M-203 | Carrying Handle |
| M-204 | Capacitor Cover |
| M-205 | Screw for Capacitor Cover |
| M-206 | Capacitor |
| M-206P | Felt |
| M-208 | Oil Tank Pile |
| M-209 | Vinyl Tube |
| M-229 | Thrust Ball Bearing |
| M-230 | Knob for Pressure Foot Rod |
| M-231 | Screw for Knob |
| M-232 | Oiling Felt for Ldller Gear |
| M-233 | Set Screw for Oiling Felt |
| M-301 | Automatic Cut-Out Switch |
| M-302 | Automatic Cut-Out |
| M-303 | Insulated Plate |
| M-304 | Set Screw |
| M-305 | Spring Washer |

Специалисты по раскройным машинам - профессиональные технологии производства и разработки, проектирование и производство оборудования для раскройных машин



21

Обеспечить профессиональное и индивидуальное производство вертикальных машин для резки ткани. Размер машины может быть изготовлен в соответствии с потребностями клиента. В настоящее время доступны 8-дюймовые и 10-дюймовые модели для настройки.

В этой машине используется мощный двигатель, произведенный на Тайване, с высокой скоростью резки и отличной выходной энергоэффективностью. Он имеет смотровое отверстие для масла, которое удобно для добавления масла.

Разрез прямой и может резаться по кривой небольшого радиуса. Он имеет низкий уровень шума, стабильную скорость, простоту в эксплуатации и функцию автоматической заточки. Это самое идеальное режущее оборудование для швейной промышленности.

Professional and customized cutting M/C from 8" and 10".

Embedded with high efficiency MIT motor, faster cutting speed! Easy to check oil level, convenient to refill!

Low noise, stable motor speed, easy to operate, and auto grinding function. Your best choice in cutting M/C!

產品規格 Technical Specifications

| | |
|-------------|--|
| Motors | 110V, 1ph, 50/60Hz 220V, 1ph, 50/60Hz Standard: Single Speed High Power: Single Speed |
| Horsepower | .65hp, 1ph / 1.25hp, 1ph |
| Weight | 34 lbs.(15.4KG) |
| Blades | Alloy Steel, Super Alloy Steel, High Speed Steel, Non-Stick Coating, Wave Edge |
| Belts | Coarse Grits 80, Medium Grits 100, Fine Grits 120 |
| Blades Size | 8in. / 10 in. |



lubrication hole convenient to refill oil
外置油孔補充油料免拆機



easy to check oil level
油量可視槽更方便確認油量

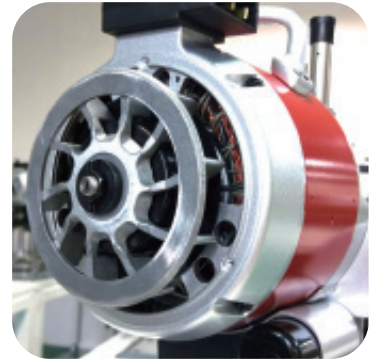

high efficiency MIT motor
faster cutting speed
台灣製馬達機芯更高效輸出



special design avoidance
abrasive belt loose
特殊磨刀器設計 有效避免脫帶

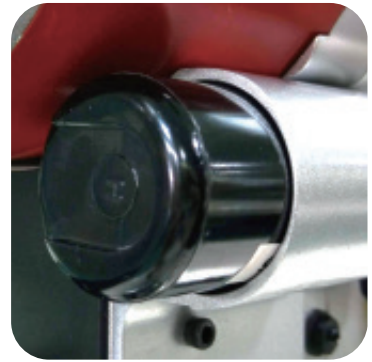

MIT capacitor voltage is more stable
台灣電容使用 電壓更穩定安全



High texture Solid wood
carrying handle
高質感實木烤漆手柄 手感舒適





| | |
|-------------------------|-----|
| WB313 2 5/8"- 1 5/8" XH | 55 |
| WB313 2 7/8"-1 7/8" H | 55 |
| WB313 2 7/8"-1 7/8" XH | 55 |
| WB313 3"-2" H | 55 |
| WB313 3"-2" XH | 55 |
| X05007001 | 8 |
| X05007001 | 27 |
| 37919 | 107 |
| 990474-0-10 | 107 |
| TC-808SB | 104 |
| TC-S230 | 105 |

Алматы (7273)495-231
Ангарск (3955)60-70-56
Архангельск (8182)63-90-72
Астрахань (8512)99-46-04
Барнаул (3852)73-04-60
Белгород (4722)40-23-64
Благовещенск (4162)22-76-07
Брянск (4832)59-03-52
Владивосток (423)249-28-31
Владикавказ (8672)28-90-48
Владимир (4922) 49-43-18
Волгоград (844)278-03-48
Вологда (8172)26-41-59
Воронеж (473)204-51-73
Екатеринбург (343)384-55-89

Ижевск (3412)26-03-58
Иваново (4932)77-34-06
Иркутск (395)279-98-46
Казань (843)206-01-48
Калининград (4012)72-03-81
Калуга (4842)92-23-67
Кемерово (3842)65-04-62
Киров (8332)68-02-04
Коломна (4966)23-41-49
Кострома (4942)77-07-48
Краснодар (861)203-40-90
Красноярск (391)204-63-61
Курск (4712)77-13-04
Курган (3522)50-90-47
Липецк (4742)52-20-81

Киргизия (996)312-96-26-47

Магнитогорск (3519)55-03-13
Москва (495)268-04-70
Мурманск (8152)59-64-93
Набережные Челны (8552)20-53-41
Нижний Новгород (831)429-08-12
Новокузнецк (3843)20-46-81
Ноябрьск (3496)41-32-12
Новосибирск (383)227-86-73
Омск (3812)21-46-40
Орел (4862)44-53-42
Оренбург (3532)37-68-04
Пенза (8412)22-31-16
Петрозаводск (8142)55-98-37
Псков (8112)59-10-37
Пермь (342)205-81-47

Россия (495)268-04-70

Ростов-на-Дону (863)308-18-15
Рязань (4912)46-61-64
Самара (846)206-03-16
Саранск (8342)22-96-24
Санкт-Петербург (812)309-46-40
Саратов (845)249-38-78
Севастополь (8692)22-31-93
Симферополь (3652)67-13-56
Смоленск (4812)29-41-54
Сочи (862)225-72-31
Ставрополь (8652)20-65-13
Сыктывкар (8212)25-95-17
Сургут (3462)77-98-35
Тамбов (4752)50-40-97
Тверь (4822)63-31-35

Казахстан (772)734-952-31

Тольяти (8482)63-91-07
Томск (3822)98-41-53
Тула (4872)33-79-87
Тюмень (3452)66-21-18
Улан-Удэ (3012)59-97-51
Ульяновск (8422)24-23-59
Уфа (347)229-48-12
Хабаровск (4212)92-98-04
Чебоксары (8352)28-53-07
Челябинск (351)202-03-61
Череповец (8202)49-02-64
Чита (3022)38-34-83
Якутск (4112)23-90-97
Ярославль (4852)69-52-93

<https://goldeneagle.nt-rt.ru> || geo@nt-rt.ru